

Item	Part	Item	Part
1	Body	19	Cover
2	Cap	20	Pin
3	Ball	21	Pin
4	Seat Assembly(5+6)	22	Anti-Static Device
5	Seat Insert	23	Spring
6	Seat Retainer	24	O-Ring
7	Stem	25	O-Ring
8	Trunnion	26	O-Ring
9	Spiral-wound Gaskets	27	O-Ring
10	Gasket	28	O-Ring
11	Gasket	29	O-Ring
12	Gasket	30	Vent Valve
13	Fire Safe Graphite Ring	31	Body Stud
14	Top Flange	32	Body Nut
15	Cover	33	Screw
16	Thrust Washer	34	Stud
17	Bearing	35	Nut
18	Bearing	36	Screw

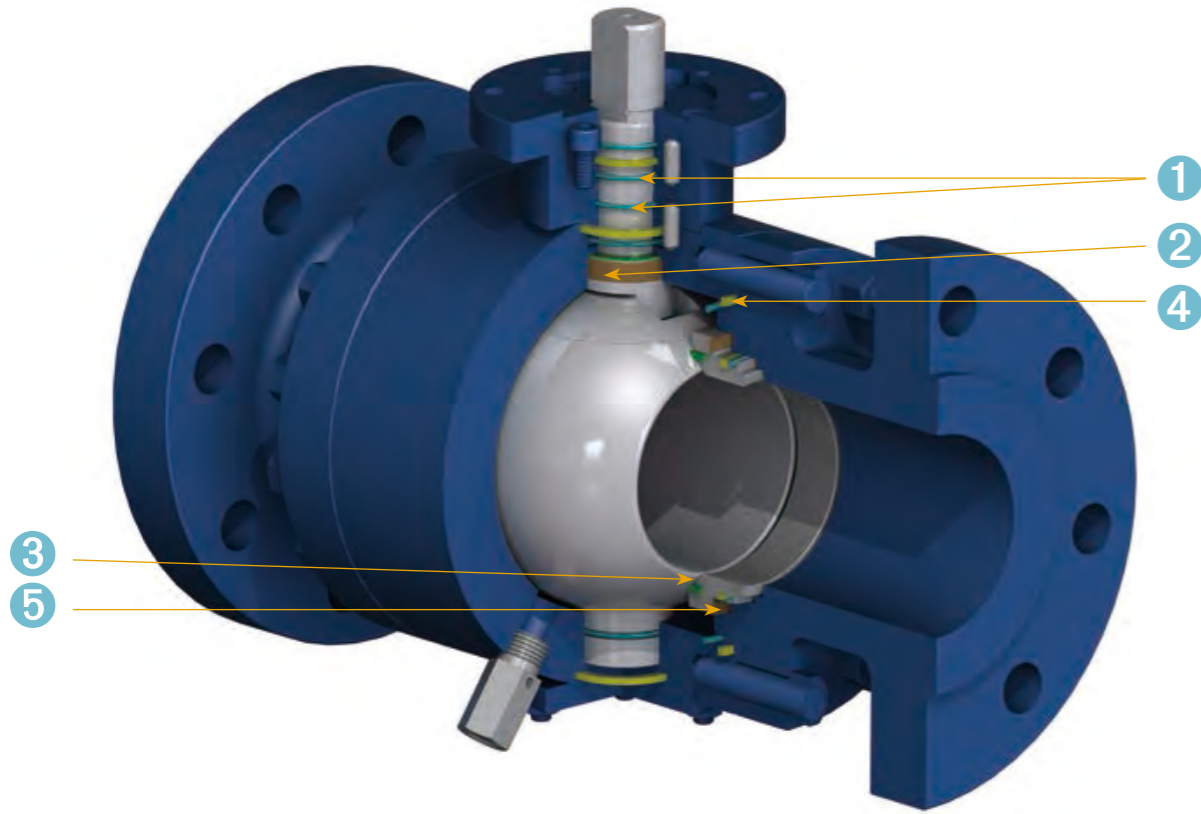

- 1 Two O-ring Seals: Prevent leakage from stem area.
- 2 Blow-out Proof Stem : Safety feature that functions to assure stem sealing at all pressures.
- 3 Back-up Metal to Metal Sealing: When primary soft-seat material is deteriorated by fire, the metal-to-metal provides shutoff.
- 4 O-ring & Gasket Combination: Prevents leakage from body connection area.
- 5 Floating Spring-loaded Seats: Assure sealing even at low pressures.

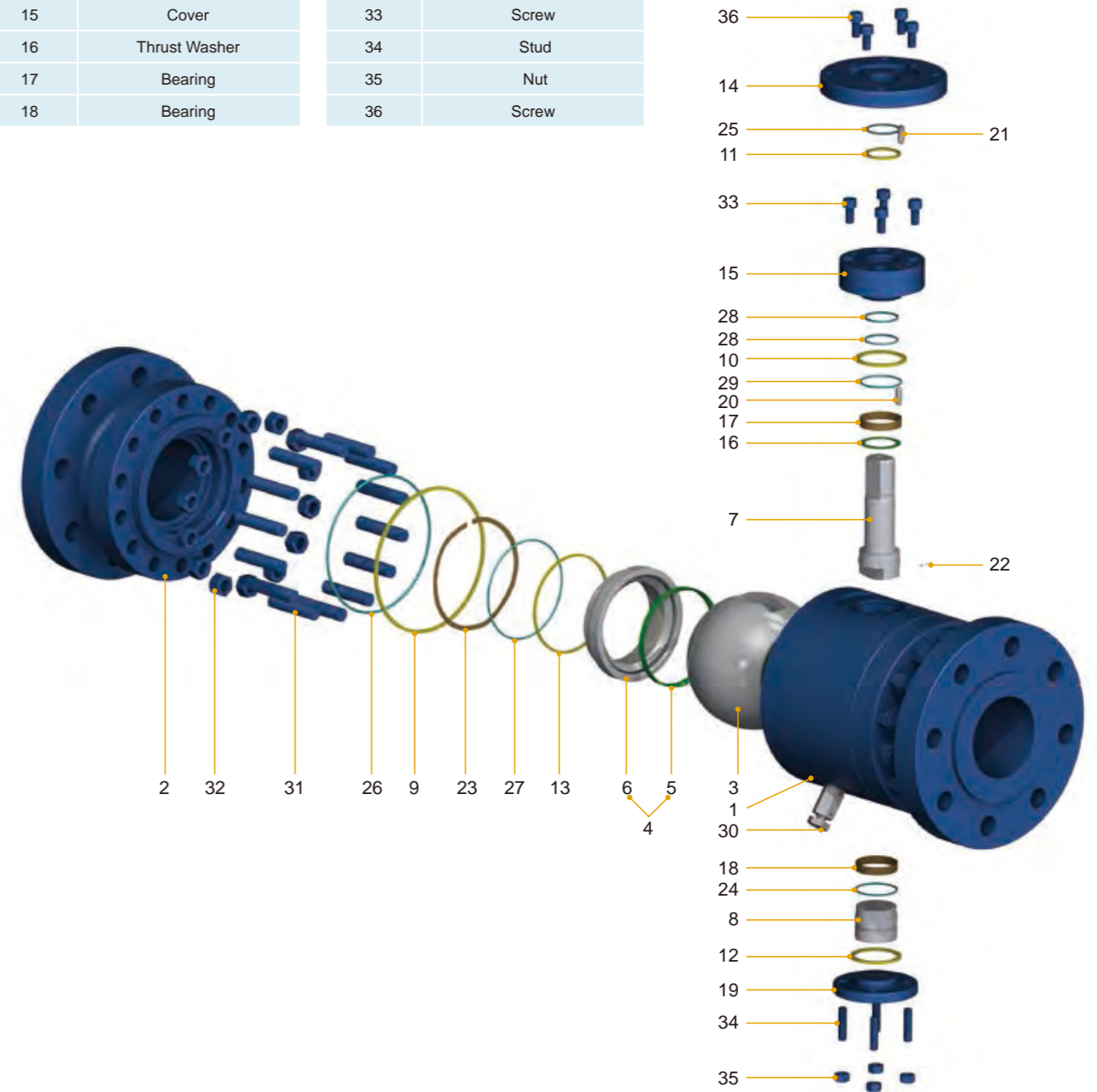

1



2



3



- 1 Metal to metal ball valve with Pneumatic actuator, 28" Class 300
- 2 Top entry trunnion mounted ball valve
- 3 Pneumatically actuated Ball valve
- 4 Electric Ball Valves
- 5 Hydraulically operated Ball Valves



4



5

How to order

Example:



Rhinoflex figure numbers are designed to cover essential features. When ordering, please show the figure numbers and a detailed description to avoid misunderstanding of your requirements.

Following descriptions provide a basic guideline in valve specification:

① Valve Sizes

Full bore:

In	2	2-1/2	3	3-1/2	4	5	6	8	10	12	14
mm	50	65	80	90	100	125	150	200	250	300	350
In	16	18	20	22	24	26	28	30	32	34	36
mm	400	450	500	550	600	650	700	750	800	850	900
In	38	40	42	44	48	52	54	56	60	--	--
mm	950	1000	1050	1100	1200	1300	1350	1400	1500		

6D Reduced Bore:

In	2x1-1/2	2-1/2x2	3x2	4x3	6x4	8x6	10x8	12x10	14x10	16x12	18x14	20x16	22x18	24x20
mm	50x40	65x50	80x50	100x80	150x100	200x150	250x200	300x250	350x250	400x300	450x350	500x400	550x450	600x500
In	26x20	28x24	30x24	32x26	34x28	36x30	38x32	40x34	42x36	46x40	48x42	54x42	56x48	60x48
mm	650x500	700x600	750x600	800x650	850x700	900x750	950x800	1000x850	1050x900	1150x1000	1200x1000	1350x1050	1400x1200	1500x1200

② Valve Types

Symbol	Valve Type	Symbol	Valve Type
BS	Side entry forged trunnion mounted type	BSP	Side entry double piston effect trunnion mounted type
BT	Side entry casting trunnion mounted type	BSE	Side entry Self relieving Double piston effect trunnion mounted type
BE	tope entry trunnion mounted type		

③ ASME Class

Code	1	3	4	6	8	9	15	25
Class (LB)	150	300	400	600	800	900	1500	2500

④ End Connections

Symbol	End
R	Raised face flanged end
J	RTJ flanged end
B	Butt-weld end

⑤ Operator

Symbol	Description	Symbol	Description
	Lever	BS	Bare shaft
G	Gear operator	H	Hydraulic actuator
M	Electric actuator	L	Gas over oil actuator
P	Pneumatic actuator	D	Electric over oil actuator

⑥ Body Materials

Steel Classification	Cast Material	Forging Material	Recommended Temperature Limits		Application
			°C	°F	
Carbon Steel	A216 Grade WCB	A105N	-29 to 425	-20 to 800	Steam, petroleum products, oil vapour, gas and general service
Carbon Steel	A216 Grade LCB	A350 Grade LF2	-46 to 350	-50 to 650	Low temperature
Carbon Steel	A216 Grade LCC	A350 Grade LF2	-46 to 350	-50 to 650	
Duplex Stainless Steel	A995 Grade 4A	A182 Grade F51	-51 to 315	-60 to 599	Corrosion resistance
Duplex Stainless Steel	A995 Grade 5A	A182 Grade F53	-51 to 315	-60 to 599	
Austenitic Stainless Steel	A351 Grade CF8M	A182 Grade F316	-196 to 815	-320 to 1500	High and low temperature corrosion resistance
Austenitic Stainless Steel	A351 Grade CF8	A182 Grade F304	-196 to 815	-320 to 1500	
Low Carbon Austenitic Stainless Steel	A351 Grade CF3M	A182 Grade F316L	-196 to 815	-320 to 1500	Cryogenic service is also available upon request
Low Carbon Austenitic Stainless Steel	A351 Grade CF3	A182 Grade F304L	-196 to 815	-320 to 1500	

⑦ Trim Codes

Seat Insert		O-ring		Stem		Ball		Seat	
Code	Material	Code	Material	Code	Material	Code	Material	Code	Material
1	PTFE	1	NBR	1	F6a	1	F6a	1	F6a
3	PEEK	2	VITON A	2	F304	2	F304	2	F304
5	DEVLON V	3	VITON AED	3	A105N/ENP	3	A105N/ENP	3	A105N/ENP
7	NYLON 12	4	VITON B	4	17-4PH	4	17-4PH	4	17-4PH
8	PCTFE	6	HNBR	5	AISI 4140/ENP	5	AISI 4140/ENP	5	AISI 4140/ENP
L	Lipseal	8	VITON GLT	6	F316	6	F316	6	F316
L	HNBR	V	FEPM	7	F304L	7	F304L	7	F304L
J	VITON	L	Lipseal	8	F316L	8	F316L	8	F316L
				9	LF2/ENP	9	LF2/ENP	9	LF2/ENP
				A	F51	A	F51	A	F51

Note: Other materials are available upon request.

		Valve Size	2"	2.5"	3"	4"	5"	6"	8"	10"	12"	14"	16"	18"	20"	24"	26"	28"	30"	32"	36"	40"	42"	48"	52"	54"	56"	60"	
API 6D Trunnion Mounted Ball Valve	Side Entry Cast Steel TM Ball Valve	150	◆	◆	◆	◆	◆	◆	◆	◆	◆	◆	◆	◆	◆	◆	◆	◆	◆	◆	◆	◆	◆	◆	◆	◆	◆	◆	
		300	◆	◆	◆	◆	◆	◆	◆	◆	◆	◆	◆	◆	◆	◆	◆	◆	◆	◆	◆	◆	◆	◆	◆	◆	◆	◆	◆
		600	◆	◆	◆	◆	◆	◆	◆	◆	◆	◆	◆	◆	◆	◆	◆	◆	◆	◆	◆	◆	◆	◆	◆	◆	◆	◆	◆
		900	◆	◆	◆	◆	◆	◆	◆	◆	◆	◆	◆	◆	◆	◆	◆	◆	◆	◆	◆	◆	◆	◆	◆	◆	◆	◆	◆
		1500	◆	◆	◆	◆	◆	◆	◆	◆	◆	◆	◆	◆	◆	◆	◆	◆	◆	◆	◆	◆	◆	◆	◆	◆	◆	◆	◆
		2500	◆	◆	◆	◆	◆	◆	◆	◆	◆	◆	◆	◆	◆	◆	◆	◆	◆	◆	◆	◆	◆	◆	◆	◆	◆	◆	◆
	Side Entry Forged Steel TM Ball Valve	150	◆	◆	◆	◆	◆	◆	◆	◆	◆	◆	◆	◆	◆	◆	◆	◆	◆	◆	◆	◆	◆	◆	◆	◆	◆	◆	
		300	◆	◆	◆	◆	◆	◆	◆	◆	◆	◆	◆	◆	◆	◆	◆	◆	◆	◆	◆	◆	◆	◆	◆	◆	◆	◆	
		600	◆	◆	◆	◆	◆	◆	◆	◆	◆	◆	◆	◆	◆	◆	◆	◆	◆	◆	◆	◆	◆	◆	◆	◆	◆	◆	
		900	◆	◆	◆	◆	◆	◆	◆	◆	◆	◆	◆	◆	◆	◆	◆	◆	◆	◆	◆	◆	◆	◆	◆	◆	◆	◆	
		1500	◆	◆	◆	◆	◆	◆	◆	◆	◆	◆	◆	◆	◆	◆	◆	◆	◆	◆	◆	◆	◆	◆	◆	◆	◆	◆	
		2500	◆	◆	◆	◆	◆	◆	◆	◆	◆	◆	◆	◆	◆	◆	◆	◆	◆	◆	◆	◆	◆	◆	◆	◆	◆	◆	
	Top Entry TM Ball Valve	150	◆	◆	◆	◆	◆	◆	◆	◆	◆	◆	◆	◆	◆	◆	◆	◆	◆	◆	◆	◆	◆	◆	◆	◆	◆	◆	
		300	◆	◆	◆	◆	◆	◆	◆	◆	◆	◆	◆	◆	◆	◆	◆	◆	◆	◆	◆	◆	◆	◆	◆	◆	◆	◆	
		600	◆	◆	◆	◆	◆	◆	◆	◆	◆	◆	◆	◆	◆	◆	◆	◆	◆	◆	◆	◆	◆	◆	◆	◆	◆	◆	
		900	◆	◆	◆	◆	◆	◆	◆	◆	◆	◆	◆	◆	◆	◆	◆	◆	◆	◆	◆	◆	◆	◆	◆	◆	◆	◆	
		1500	◆	◆	◆	◆	◆	◆	◆	◆	◆	◆	◆	◆	◆	◆	◆	◆	◆	◆	◆	◆	◆	◆	◆	◆	◆	◆	
		2500	◆	◆	◆	◆	◆	◆	◆	◆	◆	◆	◆	◆	◆	◆	◆	◆	◆	◆	◆	◆	◆	◆	◆	◆	◆	◆	

Self Relieving Seats (single piston effect)

The single piston effect is the standard design for trunnion mounted ball valves. Pressure from both upstream and downstream sides pushes the seat rings against the ball.

If the force created by the body cavity pressure is greater than the preloaded spring force plus the force created by the pressure from upstream or downstream side, the seats are pushed away from the ball. Thus, any overpressure in the body cavity is released automatically in the valves' fully open or fully closed position.

STANDARD
SINGLE PISTON EFFECT (SELF-RELIEVING SEATS)

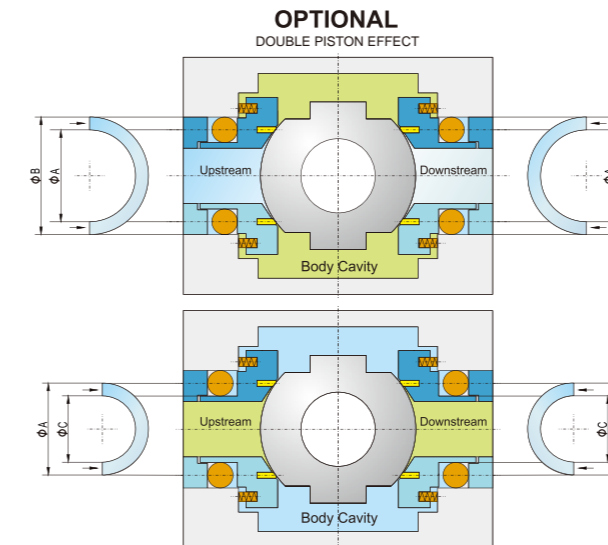
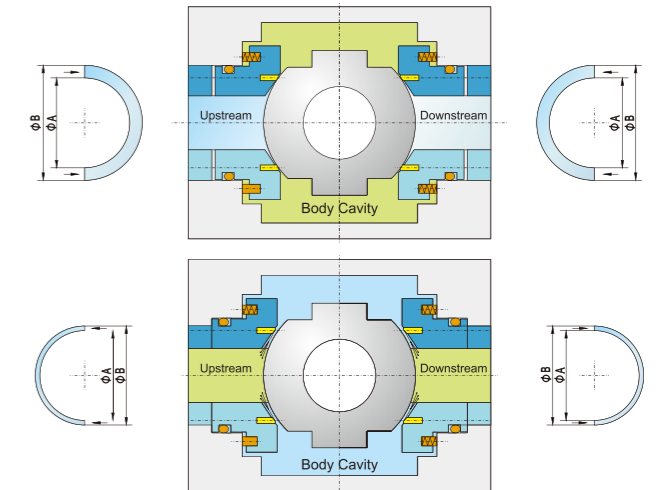

Double Piston Effect Seats (DIB-1)

Double piston effect seats are pressure energized in both directions. So the seat rings are always pushed against the ball by the pressure from upstream/downstream or from the cavity.

If the upstream seat fails, the downstream seat can still ensure a tight seal. Widely used in specific applications (high integrity required) or for some pipe pressure testing. Since double piston effect valves do not have the self-relieving function, the automatic cavity-pressure relief valve shall be provided, unless otherwise agreed.

One Self-Relieving Seat and One Double Piston Effective Seat (DIB-2)

If the force created by the body cavity pressure is greater than the preloaded spring force plus the force created by the pressure from pipeline, the cavity pressure releases via the self-relieving seat, the double piston effect seat still functions a tight seal.

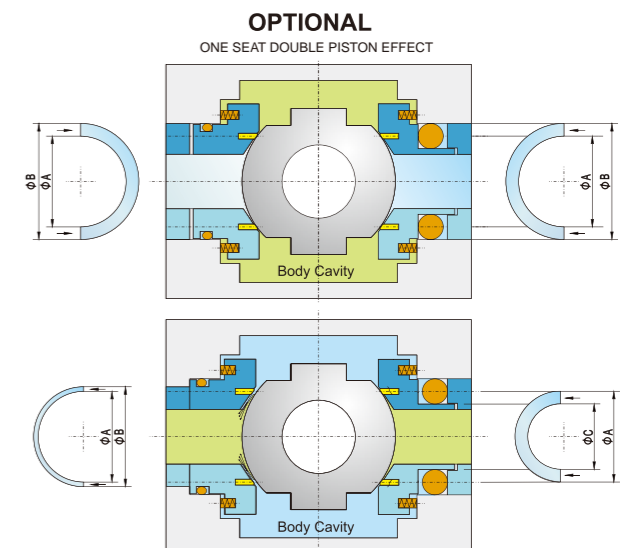

Cavity Pressure Relief

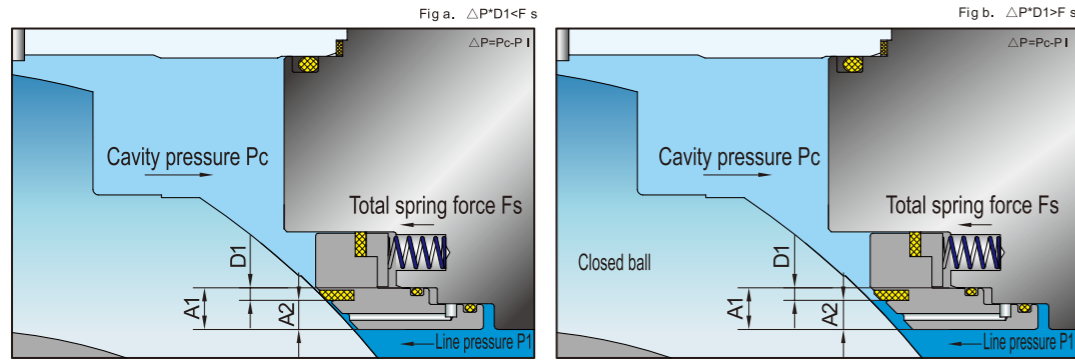

When force created by cavity pressure (P_c) is lower than the force created by line pressure (P_1), i.e. $\Delta P \cdot D_1 < F_s$, then contact between ball and seat ring is assured to provide a tight seal.

When cavity pressure is higher than seat spring force plus line pressure, i.e. $\Delta P \cdot D_1 > F_s$, the self relieving action allows the valve seat to move slightly away from the ball surface. Therefore, any overpressure inside the body cavity is discharged into the pipeline to restore the balance between the body cavity and the pipeline (either upstream or downstream side).

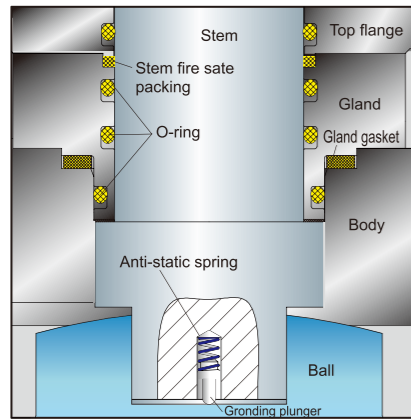

Anti Blow-out Stem

The stem is made separately from the ball. The lower end of the stem is designed with an integral shoulder to be blowout-proof.

Anti-static Device

The Antistatic Device is a standard feature of the ball valve. A spring-loaded pin assures the electrical continuity between the ball, stem and body, to avoid sparking during the turning of the stem to open and close the valve.

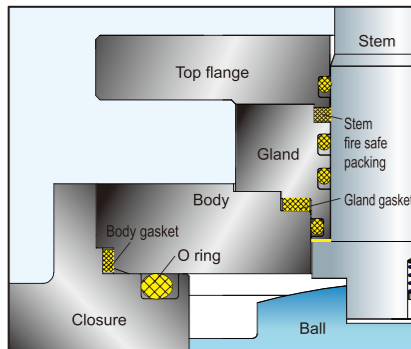

Super Fire safe design

External leakage prevention

Leakage from the valve stem area is prevented by two O-ring seals and a gland gasket. Leakage through the valve body connection is also blocked by an O-ring seal and a body gasket. After a fire deteriorated the O-rings, gland and body gasket, the firesafe stem packing prevents external leakage.

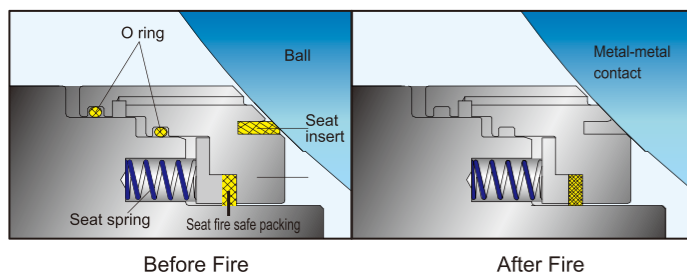

Internal leakage prevention

After the soft sealing materials are decomposed or deteriorated by fire, the edge of the metal seat preloaded by the seat spring comes into contact with the ball to shut off the process media and minimize internal leakage through the valve bore. Also the fire safe graphite packing is compressed by the seat spring to prevent process media leakage between the valve body and the seat.

Double block and bleed

In the closed position, each seat shuts off the process media independently on each side, or simultaneously on both sides of the ball, the cavity can be vented / bled via vent or drain plugs on the valve body.

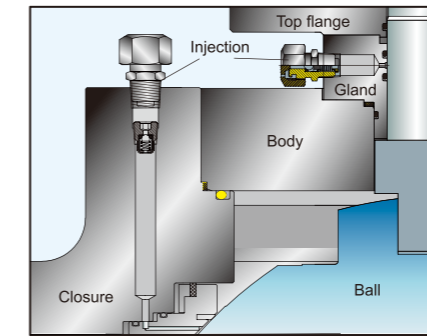

Emergency sealant injection system

will be installed on both the stem and seats. When the sealing materials (soft seat or the stem o-ring) are damaged, the seat and stem leakage can be prevented by the sealant injected into these fittings. The fitting shall include a check valve secondary means of sealing. For 4 inch and below, it could be added upon requirement.

Internal stem stop design

During actuator installation, actuator's travel stop has to be adjusted according to the fully open and fully closed position of valve. This stem stop can help to find fully open and fully close position easily.

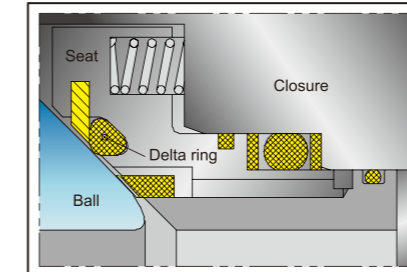
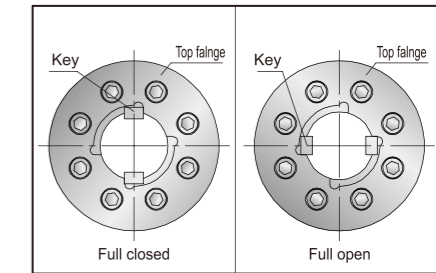

DELTA RING seat design (optional)

The material of delta ring is elastomer, which has better elasticity, can "absorb" the deviation in the ball, to obtain zero leakage easily, especially for large-sized ball or austenitic ball or full-welded ball valve. This is an optional design, not for standard.

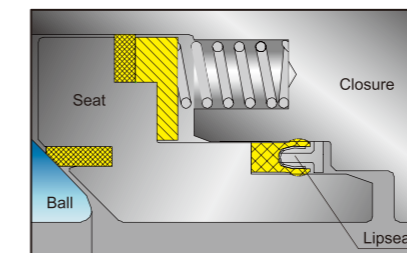

Lipseal design (optional)

Lipseal is the spring-energized seal including Elgiloy or Inconel spring and PTFE jacket. It's effective in a wide range of application, such as high resistance to corrosive chemical media, high sour gas, low temperature or cryogenic service.

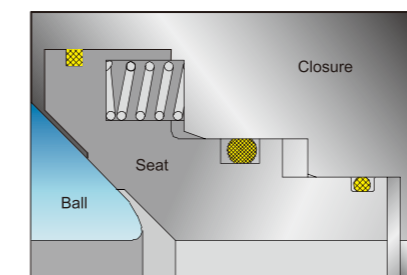

Metal-to-metal seat design (optional)

When valve is applied in the high abrasive or high temperature service, metal-to-metal seat shall be chosen.

Item	Part	Standard	Stainless Steel	Sour Service	Low Temperature Service
1	Body	ASTM A105N	ASTM A182 F316	ASTM A105N	ASTM A350 LF2
2	Cap	ASTM A105N	ASTM A182 F316	ASTM A105N	ASTM A350 LF2
3	Ball	ASTM A105N/ENP	ASTM A182 F316	ASTM A105N/ENP	ASTM A350 LF2/ENP
4	Seat Assembly(5+6)	5&6	5&6	5&6	5&6
5	Seat Insert	RPTFE/NYLON/PEEK	RPTFE/NYLON/PEEK	RPTFE/NYLON/PEEK	RPTFE/NYLON/PEEK
6	Seat Retainer	ASTM A105N/ENP	ASTM A182 F316	ASTM A105N/ENP	ASTM A350 LF2/ENP
7	Stem	ASTM A105N/ENP	ASTM A182 F316	ASTM A105N/ENP	ASTM A350 LF2/ENP
8	Trunnion	ASTM A182 F6a	ASTM A182 F316L	ASTM A182 F6a	ASTM A182 F6a
9	Spiral-wound Gaskets	316SS+Graphite	316SS+Graphite	316SS+Graphite	316SS+Graphite
10	Gasket	316SS+Graphite	316SS+Graphite	316SS+Graphite	316SS+Graphite
11	Gasket	316SS+Graphite	316SS+Graphite	316SS+Graphite	316SS+Graphite
12	Gasket	316SS+Graphite	316SS+Graphite	316SS+Graphite	316SS+Graphite
13	Fire Safe Graphite Ring	316SS+Graphite	316SS+Graphite	316SS+Graphite	316SS+Graphite
14	Top Flange	ASTM A105N	ASTM A182 F304	ASTM A105N	ASTM A350 LF2
15	Cover	ASTM A105N	ASTM A182 F316	ASTM A105N	ASTM A350 LF2
16	Thrust Washer	PTFE	PTFE	PTFE	PTFE
17	Bearing	316SS+PTFE+MoS2	316SS+PTFE+MoS2	316SS+PTFE+MoS2	316SS+PTFE+MoS2
18	Bearing	316SS+PTFE	316SS+PTFE	316SS+PTFE	316SS+PTFE
19	Cover	ASTM A105N	ASTM A182 F316	ASTM A105N	ASTM A350 LF2
20	Pin	Carbon Steel	Stainless Steel	Carbon Steel	Carbon Steel
21	Pin	Carbon Steel	Stainless Steel	Carbon Steel	Carbon Steel
22	Anti-Static Device	Stainless Steel	Stainless Steel	Stainless Steel	Stainless Steel
23	Spring	Inconel X-750	Inconel X-750	Inconel X-750	Inconel X-750
24	O-Ring	HNBR/VITON	HNBR/VITON	HNBR/VITON	HNBR/VITON
25	O-Ring	NBR	NBR	NBR	NBR
26	O-Ring	HNBR/VITON	HNBR/VITON	HNBR/VITON	HNBR/VITON
27	O-Ring	HNBR/VITON	HNBR/VITON	HNBR/VITON	HNBR/VITON
28	O-Ring	HNBR/VITON	HNBR/VITON	HNBR/VITON	HNBR/VITON
29	O-Ring	HNBR/VITON	HNBR/VITON	HNBR/VITON	HNBR/VITON
30	Vent Valve	Stainless Steel	Stainless Steel	Stainless Steel	Stainless Steel
31	Body Stud	ASTM A193-B7	ASTM A193-B8	ASTM A193-B7M	ASTM A320-L7M
32	Body Nut	ASTM A194-2H	ASTM A194-8	ASTM A194-2HM	ASTM A194-7M
33	Screw	ASTM A193-B7	ASTM A193-B8	ASTM A193-B7M	ASTM A320-L7M
34	Body Stud	ASTM A193-B7	ASTM A193-B8	ASTM A193-B7M	ASTM A320-L7M
35	Body Nut	ASTM A194-2H	ASTM A194-8	ASTM A194-2HM	ASTM A194-7M
36	Screw	ASTM A193-B7	ASTM A193-B8	ASTM A193-B7M	ASTM A320-L7M

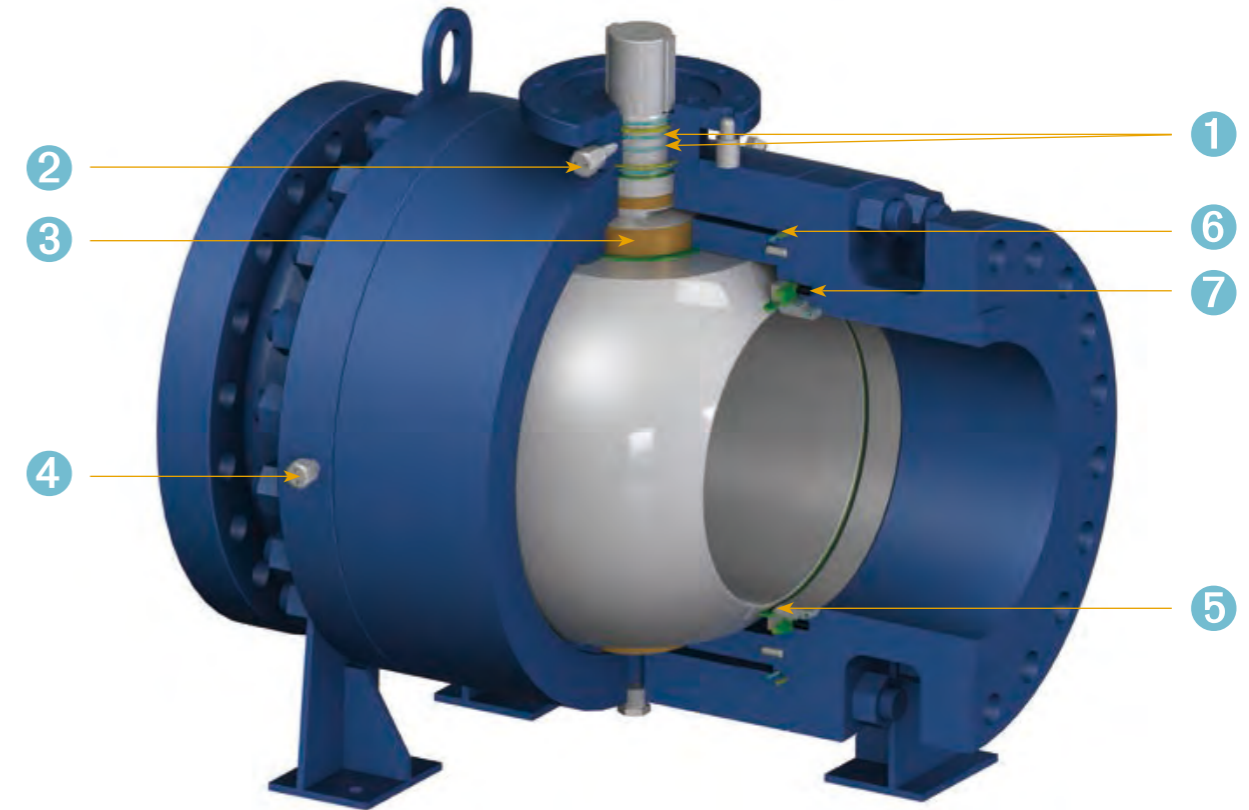

- 1 Two O-ring Seals: Prevent leakage from stem area.
- 2 Emergency Sealant Injection Fitting: Allows external interventions to prevent stem leakage.
- 3 Blow-out Proof Stem : Safety feature that functions to assure stem sealing at all pressures.
- 4 Emergency Sealant Injection Fitting: Allows external intervention to prevent seat leakage.
- 5 Back-up Metal to Metal Sealing: When primary soft-seat material is deteriorated by fire, the metal-to-metal provides shutoff.
- 6 O-ring & Gasket Combination: Prevents leakage from body connection area.
- 7 Floating Spring-loaded Seats: Assure sealing even at low pressures.

Trunnion Mounted Ball Valve (6") & above

Material Specifications

Item	Part	Item	Part
1	Body	22	O-Ring
2	Cap	23	O-Ring
3	Ball	24	O-Ring
4	Seat Assembly(5+6)	25	O-Ring
5	Seat Insert	26	O-Ring
6	Seat Retainer	27	O-Ring
7	Stem	28	Pin
8	Cover	29	Pin
9	Top Flange	30	Pin
10	Bearing Support	31	Pin
11	Support Legs	32	Anti-Static Device
12	Lifting Lugs	33	Key
13	Thrust Washer	34	Spring
14	Thrust Washer	35	Body Stud
15	Bearing	36	Body Nut
16	Bearing	37	Screw
17	Seat Follower	38	Screw
18	Gasket	39	Vent Valve
19	Gasket	40	Plug
20	Gasket	41	Injection
21	Fire Safe Graphite Ring	42	Injection

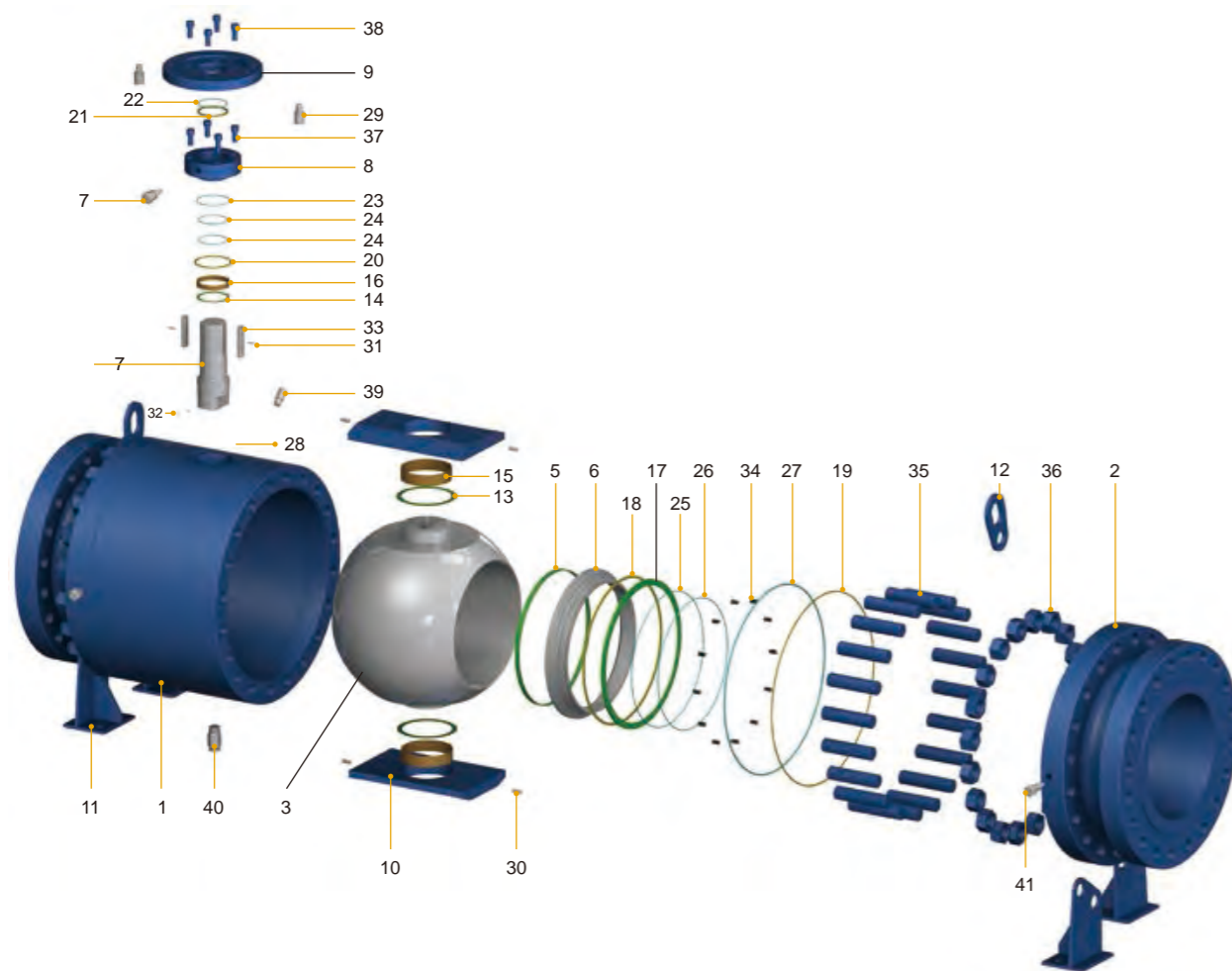

Material Specifications

Trunnion Mounted Ball Valve (6") & above

Item	Part	Standard	Stainless Steel	Sour Service	Low Temperature Service
1	Body	ASTM A105N	ASTM A182 F316	ASTM A105N	ASTM A350 LF2
2	Cap	ASTM A105N	ASTM A182 F316	ASTM A105N	ASTM A350 LF2
3	Ball	ASTM A105N/ENP	ASTM A182 F316	ASTM A105N/ENP	ASTM A350 LF2/ENP
4	Seat Assembly(5+6)	5&6	5&6	5&6	5&6
5	Seat Insert	RPTFE/NYLON/PEEK	RPTFE/NYLON/PEEK	RPTFE/NYLON/PEEK	RPTFE/NYLON/PEEK
6	Seat Retainer	ASTM A105N/ENP	ASTM A182 F316	ASTM A105N/ENP	ASTM A350 LF2/ENP
7	Stem	ASTM A105N/ENP	ASTM A182 F316	ASTM A105N/ENP	ASTM A350 LF2/ENP
8	Cover	ASTM A105N	ASTM A182 F316	ASTM A105N	ASTM A350 LF2
9	Top Flange	ASTM A105N	ASTM A182 F304	ASTM A105N	ASTM A350 LF2
10	Bearing Support	ASTM A588B/ENP	ASTM A351-CF3M	ASTM A588B/ENP	ASTM A588B/ENP
11	Support Legs	Carbon Steel	Carbon Steel	Carbon Steel	Carbon Steel
12	Lifting Lugs	Carbon Steel	Carbon Steel	Carbon Steel	Carbon Steel
13	Thrust Washer	PTFE	PTFE	PTFE	PTFE
14	Thrust Washer	PTFE	PTFE	PTFE	PTFE
15	Bearing	316SS+PTFE	316SS+PTFE	316SS+PTFE	316SS+PTFE
16	Bearing	316SS+PTFE+MoS2	316SS+PTFE+MoS2	316SS+PTFE+MoS2	316SS+PTFE+MoS2
17	Seat Follower	ASTM A105N/ENP	ASTM A182 F316	ASTM A105N/ENP	ASTM A350 LF2/ENP
18	Gasket	316SS+Graphite	316SS+Graphite	316SS+Graphite	316SS+Graphite
19	Gasket	316SS+Graphite	316SS+Graphite	316SS+Graphite	316SS+Graphite
20	Gasket	316SS+Graphite	316SS+Graphite	316SS+Graphite	316SS+Graphite
21	Fire Safe Graphite Ring	316SS+Graphite	316SS+Graphite	316SS+Graphite	316SS+Graphite
22	O-Ring	NBR	NBR	NBR	NBR
23	O-Ring	HNBR/VITON	HNBR/VITON	HNBR/VITON	HNBR/VITON
24	O-Ring	HNBR/VITON	HNBR/VITON	HNBR/VITON	HNBR/VITON
25	O-Ring	HNBR/VITON	HNBR/VITON	HNBR/VITON	HNBR/VITON
26	O-Ring	HNBR/VITON	HNBR/VITON	HNBR/VITON	HNBR/VITON
27	O-Ring	HNBR/VITON	HNBR/VITON	HNBR/VITON	HNBR/VITON
28	Pin	Carbon Steel	Stainless Steel	Carbon Steel	Stainless Steel
29	Pin	Carbon Steel	Carbon Steel	Carbon Steel	Carbon Steel
30	Pin	Stainless Steel	Stainless Steel	Stainless Steel	Stainless Steel
31	Pin	Stainless Steel	Stainless Steel	Stainless Steel	Stainless Steel
32	Anti-Static Device	Stainless Steel	Stainless Steel	Stainless Steel	Stainless Steel
33	Key	Stainless Steel	Stainless Steel	Stainless Steel	Stainless Steel
34	Spring	Inconel X-750	Inconel X-750	Inconel X-750	Inconel X-750
35	Body Stud	ASTM A193-B7	ASTM A193-B8	ASTM A193-B7M	ASTM A320-L7M
36	Body Nut	ASTM A194-2H	ASTM A194-8	ASTM A194-2HM	ASTM A194-7M
37	Screw	ASTM A193-B7	A2-70	ASTM A193-B7	ASTM A320-L7M
38	Screw	ASTM A193-B7	A2-70	ASTM A193-B7	ASTM A320-L7M
39	Vent Valve	Stainless Steel	Stainless Steel	Stainless Steel	Stainless Steel
40	Plug	Stainless Steel	Stainless Steel	Stainless Steel	Stainless Steel
41	Injection	Stainless Steel	Stainless Steel	Stainless Steel	Stainless Steel
42	Injection	Stainless Steel	Stainless Steel	Stainless Steel	Stainless Steel

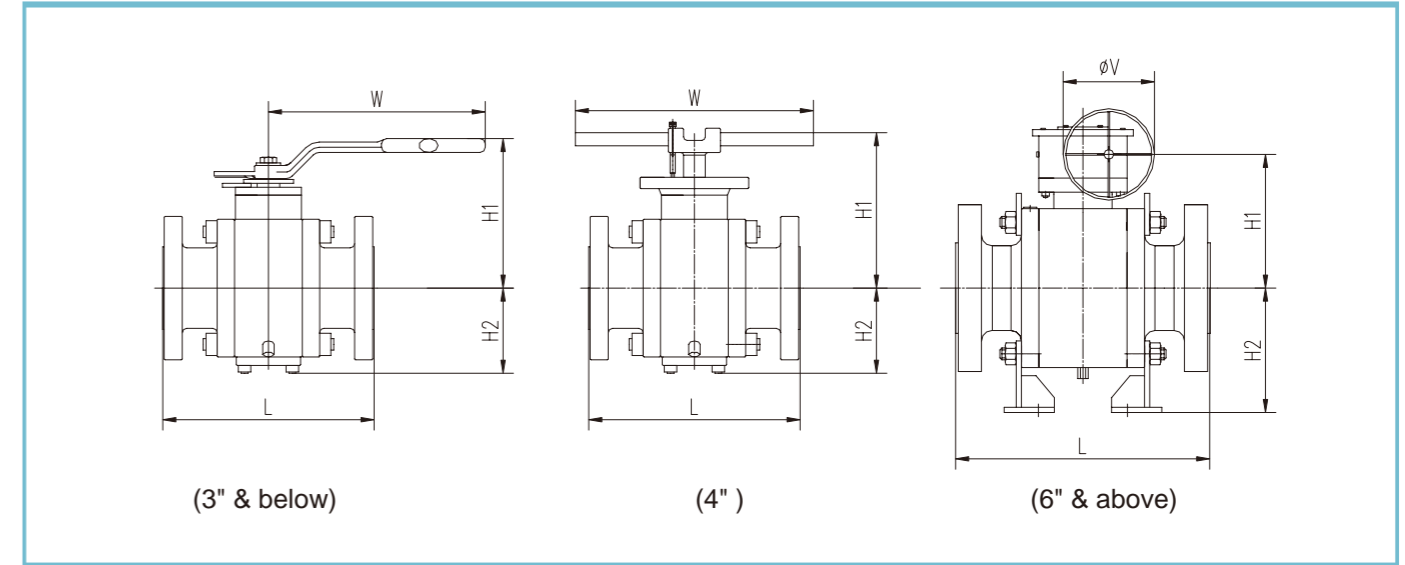
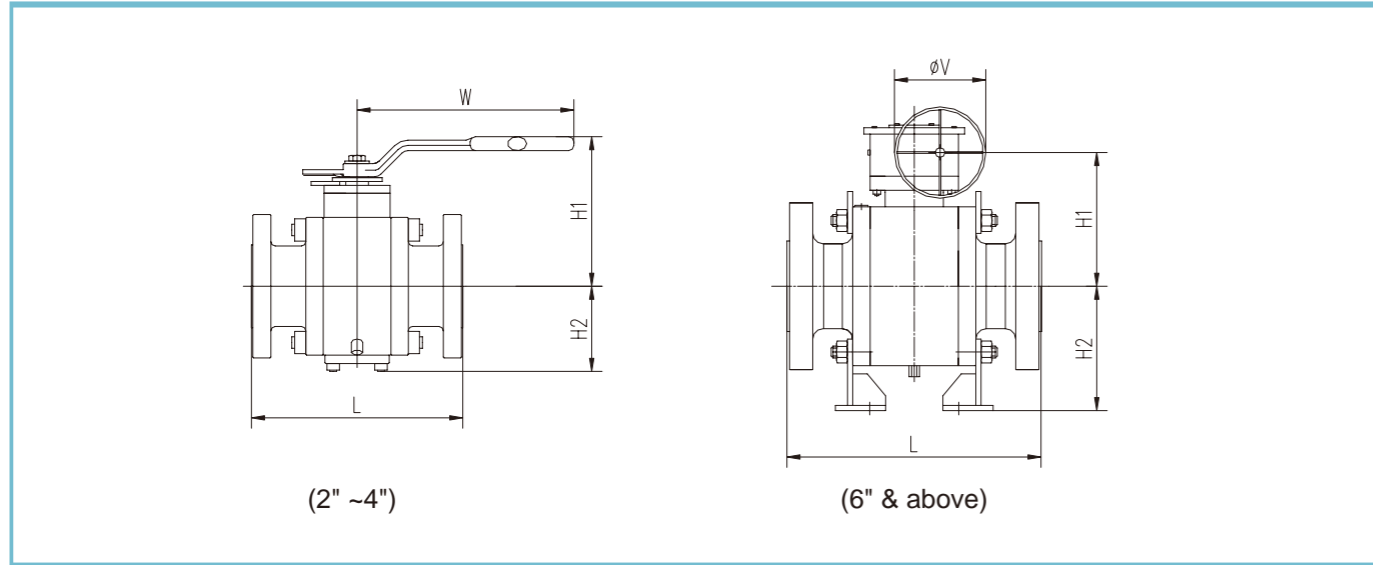

Class 150 Dimensions and weight

In		D		L				H1		H2		W		V		Weight	
				RF		BW											
in	mm	in	mm	in	mm	in	mm	in	mm	in	mm	in	mm	in	mm	lb	Kg
2	50	1.93	49	7.01	178	8.50	216	6.78	172.1	3.52	89.3	12.99	330			41.89	19
3	80	2.91	74	7.99	203	11.14	283	7.91	200.8	4.20	106.8	15.75	400			57.32	26
4	100	3.94	100	9.02	229	12.01	305	8.75	222.3	4.98	126.5	15.75	400			103.62	47
6	150	5.91	150	15.51	394	17.99	457	10.85	275.5	10.04	255.0			15.75	400	352.74	160
8	200	7.91	201	17.99	457	20.51	521	12.32	313.0	11.46	291.0			15.75	400	573.20	260
10	250	9.92	252	20.98	533	22.01	559	14.25	362.0	13.11	333.0			23.62	600	983.26	446
12	300	11.93	303	24.02	610	25.00	635	15.73	399.5	14.57	370.0			23.62	600	1532.21	695
14	350	13.15	334	27.01	686	30.00	762	20.12	511.0	15.53	394.5			23.62	600	1975.34	896
16	400	15.16	385	30.00	762	32.99	838	21.56	547.5	16.93	430.0			23.62	600	2850.57	1293
18	450	17.17	436	34.02	864	35.98	914	23.05	585.5	18.41	467.5			23.62	600	3333.39	1512
20	500	19.17	487	35.98	914	39.02	991	24.57	624.0	19.90	505.5			23.62	600	3935.25	1785
22	550	21.18	538	39.02	991	42.99	1092	27.80	706.0	21.78	553.3			23.62	600	5138.97	2331
24	600	23.19	589	42.01	1067	45.00	1143	29.96	761.0	23.26	590.8			27.56	700	6393.40	2900
26	650	24.92	633	45.00	1143	49.02	1245	31.40	797.5	24.68	626.8			27.56	700	7407.52	3360
28	700	26.93	684	49.02	1245	52.99	1346	28.76	730.5	26.32	668.5			29.92	760	9363.57	4247
30	750	28.94	735	50.98	1295	55.00	1397	30.26	768.5	27.80	706.0			29.92	760	11157.58	5061
32	800	30.67	779	54.02	1372	60.00	1524	31.56	801.5	29.07	738.5			29.92	760	12708.53	5765
34	850	32.68	830	57.99	1473	64.02	1626	33.03	839.0	30.53	775.5			29.92	760	15518.76	7039
36	900	34.41	874	60.00	1524	67.99	1727	35.30	896.5	31.85	809.0			29.92	760	17627.59	7996
40	1000	38.43	976	67.99	1727	70.08	1780	44.98	1142.5	35.57	903.5			29.92	760	25525.86	11578
42	1050	40.16	1020	72.01	1829	72.01	1829	46.30	1176.0	36.85	936.0			29.92	760	28032.85	12716
48	1200	45.91	1166	78.54	1995	78.54	1995	50.57	1284.5	41.24	1047.5			29.92	760	42500.66	19278
54	1350	51.65	1312	—	—	—	—	54.19	1376.5	42.87	1089.0			35.43	900	75464.14	34230
56	1400	53.54	1360	97.99	2489	97.99	2489	57.74	1466.5	44.81	1138.3			39.37	1000	84492.06	38325
60	1500	57.40	1458	—	—	—	—	61.36	1558.5	47.65	1210.3			39.37	1000	90510.67	41055

Class 300 Dimensions and weight

In		D		L				H1		H2		W		V		Weight	
				RF		BW											
in	mm	in	mm	in	mm	in	mm	in	mm	in	mm	in	mm	in	mm	lb	Kg
2	50	1.93	49	8.50	216	8.50	216	6.78	172.1	3.59	91.3	12.99	330			66.14	30
3	80	2.91	74	11.14	283	11.14	283	7.91	200.8	3.38	85.8	15.75	400			105.82	48
4	100	3.94	100	12.01	305	12.01	305	11.10	282.0	5.59	142	32.09	815			154.32	70
6	150	5.91	150	15.87	403	17.99	457	10.85	275.5	10.04	255.0			15.75	400	418.88	190
8	200	7.91	201	19.76	502	20.51	521	12.28	312.0	11.61	295.0			19.69	500	694.46	315
10	250	9.92	252	22.36	568	22.01	559	14.29	363.0	13.29	337.5			23.62	600	1172.86	532
12	300	11.93	303	25.51	648	25.00	635	16.08	408.5	14.93	379.3			23.62	600	1814.40	823
14	350	13.15	334	30.00	762	30.00	762	20.12	511.0	15.71	399.0			23.62	600	2204.62	1000
16	400	15.16	385	32.99	838	32.99	838	21.93	557.0	17.29	439.3			23.62	600	3064.42	1390
18	450	17.17	436	35.98	914	35.98	914	24.78	629.5	18.96	481.5			23.62	600	4159.02	1887
20	500	19.17	487	39.02	991	39.02	991	26.99	685.5	20.61	523.5			27.56	700	4583.40	2079
22	550	21.18	538	42.99	1092	42.99	1092	28.84	732.5	22.13	562.0			27.56	700	5703.79	2587
24	600	23.19	589	45.00	1143	45.00	1143	26.02	661.0	23.78	604.0			29.92	760	7008.49	3179
26	650	24.92	633	49.02	1245	49.02	1245	27.72	704.0	25.35	644.0			29.92	760	9052.83	4106
28	700	26.93	684	52.99	1346	52.99	1346	30.45	773.5	27.05	687.0			29.92	760	11094.75	5033
30	750	28.94	735	55.00	1397	55.00	1397	31.95	811.5	28.52	724.5			29.92	760	13556.21	6149
32	800	30.67	779	60.00	1524	60.00	1524	33.31	846.0	29.98	761.5			29.92	760	15132.51	6864
34	850	32.68	830	64.02	1626	64.02	1626	34.78	883.5	31.46	799.0			29.92	760	17872.85	8107
36	900	34.41	874	67.99	1727	67.99	1727	42.81	1087.5	33.37	847.5			29.92	760	20455.57	9279
40	1000	38.43	976	75.98	1930	75.98	1930	45.93	1166.5	36.61	930.0			29.92	760	27160.92	12320
42	1050	40.16	1020	82.01	2083	82.01	2083	49.69	1262.0	37.89	962.5			31.50	800	31647.32	14355
48	1200	45.91	1166	85.43	2170	85.43	2170	55.43	1408.0	39.22	996.3			35.43	900	46076.56	20900
54	1350	51.65	1312	—	—	—	—	56.93	1446.0	42.87	1089.0			35.43307087	900	79057.67	35860
56	1400	53.54	1360	100.12	2543	100.12	2543	57.74	1466.5	44.81	1138.3			39.37007874	1000	88515.49	40150
60	1500	57.40	1458	—	—	—	—	62.54	1588.5	47.65	1210.3				1000	94820.71	43010

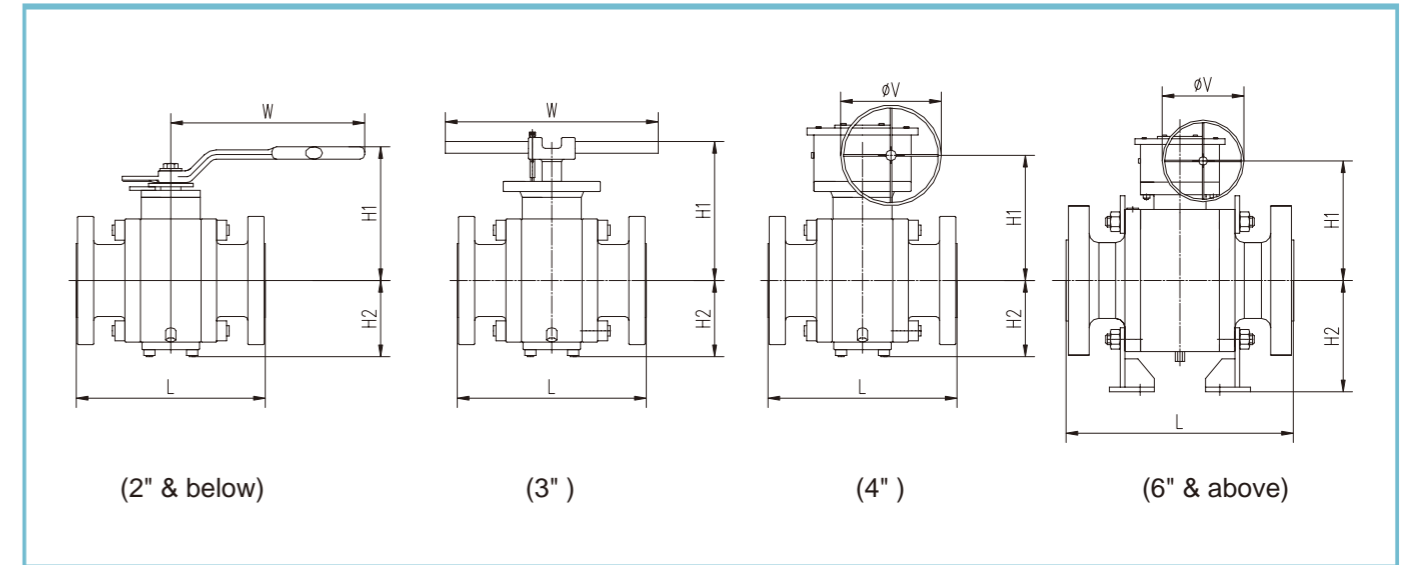
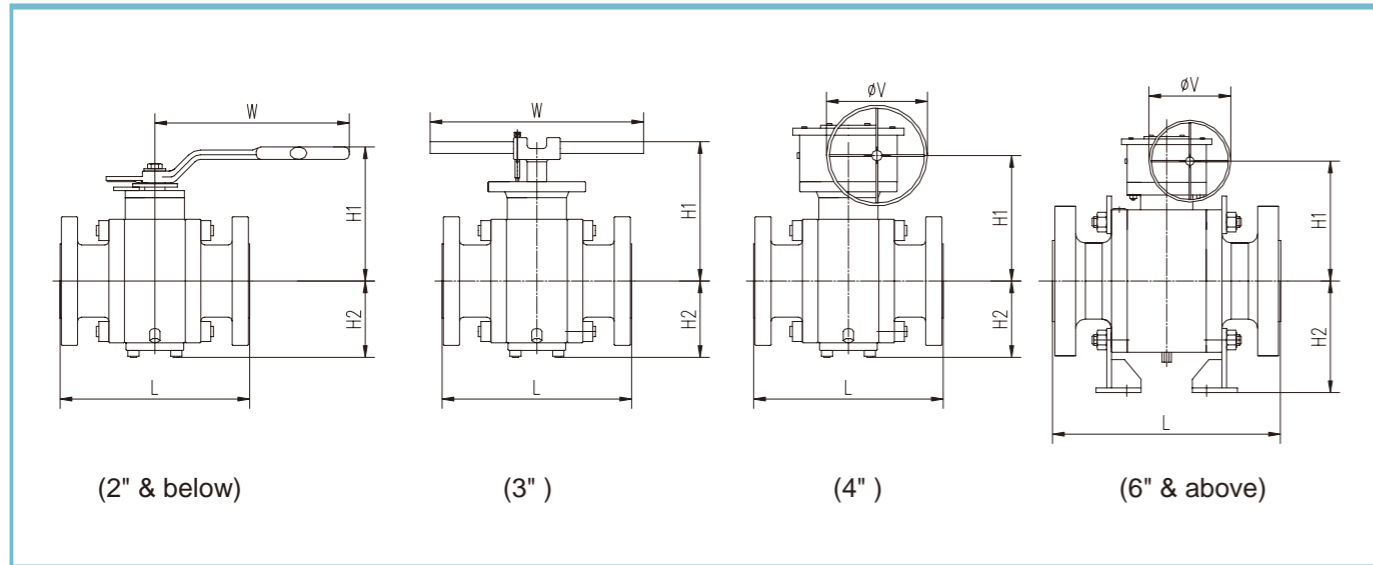

Class 400 Dimensions and weight

In	D		L						H1	H2	W	V	Weight	
	in	mm	RF	BW		RTJ		lb					Kg	
2	50	1.93 49	11.50 292	11.50 292	11.61 295	7.33 186.3	3.59 91.3	15.75 400					72.75	33
3	80	2.91 74	14.02 356	14.02 356	14.13 359	10.28 261.0	4.07 103.3	32.09 815					149.91	68
4	100	3.94 100	15.98 406	15.98 406	16.14 410	8.25 209.5	4.93 125.3				11.81 300	257.94	117	
6	150	5.91 150	19.49 495	19.49 495	19.61 498	10.85 275.5	10.04 255.0				15.75 400	595.25	270	
8	200	7.91 201	23.50 597	23.50 597	23.62 600	12.28 312.0	11.61 295.0				19.69 500	784.84	356	
10	250	9.92 252	26.50 673	26.50 673	26.61 676	14.29 363.0	13.29 337.5				23.62 600	1245.61	565	
12	300	11.93 303	30.00 762	30.00 762	30.12 765	19.49 495.0	15.12 384.0				23.62 600	2204.62	1000	
14	350	13.15 334	32.52 826	32.52 826	32.64 829	20.51 521.0	16.08 408.5				23.62 600	2936.55	1332	
16	400	15.16 385	35.51 902	35.51 902	35.63 905	23.27 591.0	17.64 448.0				23.62 600	4100.59	1860	
18	450	17.17 436	38.50 978	38.50 978	38.62 981	25.26 641.5	19.29 490.0				23.62 600	4188.78	1900	
20	500	19.17 487	41.50 1054	41.50 1054	41.73 1060	27.62 701.5	20.94 532.0				27.56 700	5407.93	2453	
22	550	21.18 538	45.00 1143	45.00 1143	45.39 1153	25.10 637.5	22.83 580.0				29.92 760	7129.74	3234	
24	600	23.19 589	48.50 1232	48.50 1232	48.86 1241	26.59 675.5	24.19 614.5				29.92 760	9603.32	4356	
26	650	24.92 633	51.50 1308	51.50 1308	52.01 1321	29.63 752.5	26.22 666.0				29.92 760	10961.37	4972	
28	700	26.93 684	55.00 1397	55.00 1397	55.51 1410	37.20 945.0	27.83 707.0				29.92 760	13216.70	5995	
30	750	28.94 735	60.00 1524	60.00 1524	60.51 1537	38.68 982.5	29.31 744.5				29.92 760	15229.51	6908	
32	800	30.67 779	65.00 1651	65.00 1651	65.63 1667	40.00 1016.0	30.79 782.0				29.92 760	17824.35	8085	
34	850	32.68 830	70.00 1778	70.00 1778	70.63 1794	41.89 1064.0	32.58 827.5				29.92 760	19958.42	9053	
36	900	34.41 874	74.02 1880	74.02 1880	74.61 1895	43.21 1097.5	33.90 861.0				29.92 760	24493.33	11110	
40	1000	38.43 976	85.00 2159	85.00 2159	— —	43.43 1103.0	33.73 856.8				35.43 900	32932.61	14938	
42	1050	40.16 1020	85.63 2175	85.63 2175	— —	47.15 1197.5	35.01 889.3				31.50 800	37370.51	16951	
48	1200	45.91 1166	95.87 2435	95.87 2435	— —	52.15 1324.5	39.22 996.3				31.50 800	53109.30	24090	
54	1350	51.65 1312	— —	— —	— —	57.22 1453.5	42.89 1089.5				39.37 1000	79057.67	35860	
56	1400	53.54 1360	106.69 2710	106.69 2710	— —	58.52 1486.5	44.81 1138.3				39.37 1000	109435.13	49639	
60	1500	57.40 1458	— —	— —	— —	62.54 1588.5	47.65 1210.3				39.37 1000	116403.94	52800	

Class 600 Dimensions and weight

In	D		L						H1	H2	W	V	Weight	
	in	mm	RF	BW		RTJ		lb					Kg	
2	50	1.93 49	11.50 292	11.50 292	11.61 295	7.33 186.3	3.59 91.3	15.75 400					83.78	38
3	80	2.91 74	14.02 356	14.02 356	14.13 359	10.28 261.0	4.07 103.3	32.09 815					171.96	78
4	100	3.94 100	17.01 432	17.01 432	17.13 435	8.56 217.5	4.07 103.3				15.75 400	257.94	117	
6	150	5.91 150	22.01 559	22.01 559	22.13 562	11.20 284.5	10.37 263.5				15.75 400	606.27	275	
8	200	7.91 201	25.98 660	25.98 660	26.14 664	12.68 322.0	11.98 304.3				19.69 500	965.62	438	
10	250	9.92 252	30.98 787	30.98 787	31.14 791	14.96 380.0	13.82 351.0				23.62 600	1631.42	740	
12	300	11.93 303	32.99 838	32.99 838	33.11 841	20.00 508.0	15.45 392.5				23.62 600	2270.76	1030	
14	350	13.15 334	35.00 889	35.00 889	35.12 892	22.32 567.0	16.57 421.0				23.62 600	2969.62	1347	
16	400	15.16 385	39.02 991	39.02 991	39.13 994	24.13 613.0	18.23 463.0				23.62 600	4321.06	1960	
18	450	17.17 436	42.99 1092	42.99 1092	43.11 1095	26.56 674.5	19.90 505.5				27.56 700	4817.09	2185	
20	500	19.17 487	47.01 1194	47.01 1194	47.24 1200	23.78 604.0	21.59 548.5				29.92 760	7165.02	3250	
22	550	21.18 538	50.98 1295	50.98 1295	51.38 1305	26.71 678.5	23.70 602.0				29.92 760	8172.53	3707	
24	600	23.19 589	55.00 1397	55.00 1397	55.39 1407	28.25 717.5	25.24 641.0				29.92 760	9810.56	4450	
26	650	24.92 633	57.01 1448	57.01 1448	57.52 1461	30.65 778.5	27.26 692.5				29.92 760	13568.11	6154	
28	700	26.93 684	60.98 1549	60.98 1549	61.50 1562	38.11 968.0	28.72 729.5				29.92 760	14963.20	6787	
30	750	28.94 735	65.00 1651	65.00 1651	65.51 1664	39.86 1012.5	30.53 775.5				29.92 760	16518.78	7493	
32	800	30.67 779	70.00 1778	70.00 1778	70.63 1794	41.18 1046.0	31.81 808.0				35.43 900	19321.29	8764	
34	850	32.68 830	75.98 1930	75.98 1930	76.61 1946	42.68 1084.0	33.27 845.0				35.43 900	20889.22	9475	
36	900	34.41 874	82.01 2083	82.01 2083	82.64 2099	46.44 1179.5	34.94 887.5				31.50 800	26296.71	11928	
40	1000	38.43 976	85.00 2159	85.00 2159	— —	43.52 1105.5	33.83 859.3				35.43 900	36296.86	16464	
42	1050	40.16 1020	85.63 2175	85.63 2175	— —	47.24 1200.0	35.11 891.8				31.50 800	40519.15	18379	
48	1200	45.91 1166	95.87 2435	95.87 2435	— —	57.80 1468.0	39.32 998.8				31.50 800	59754.02	27104	
54	1350	51.65 1312	— —	— —	— —	58.78 1493.0	43.23 1098.0				39.37 1000	80495.09	36512	
56	1400	53.54 1360	106.69 2710	106.69 2710	— —	59.80 1519.0	44.91 1140.8				39.37 1000	111423.96	50541	
60	1500	57.40 1458	— —	— —	— —	62.64 1591.0	47.75 1212.8				39.37 1000	118520.37	53760	

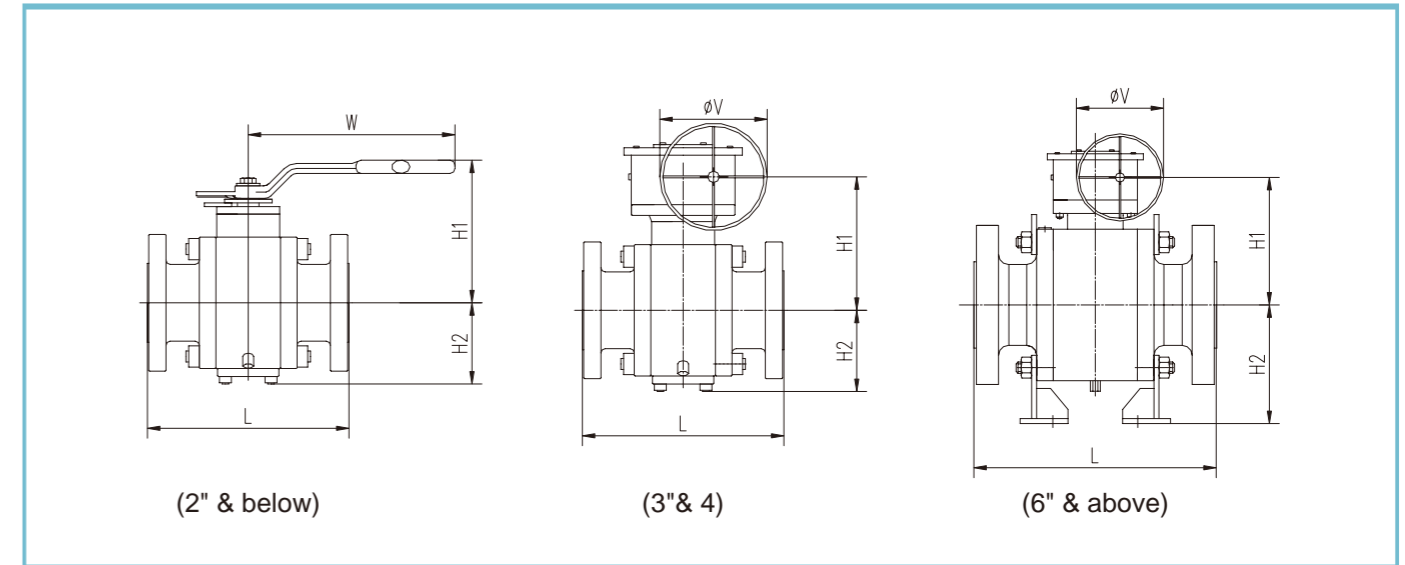
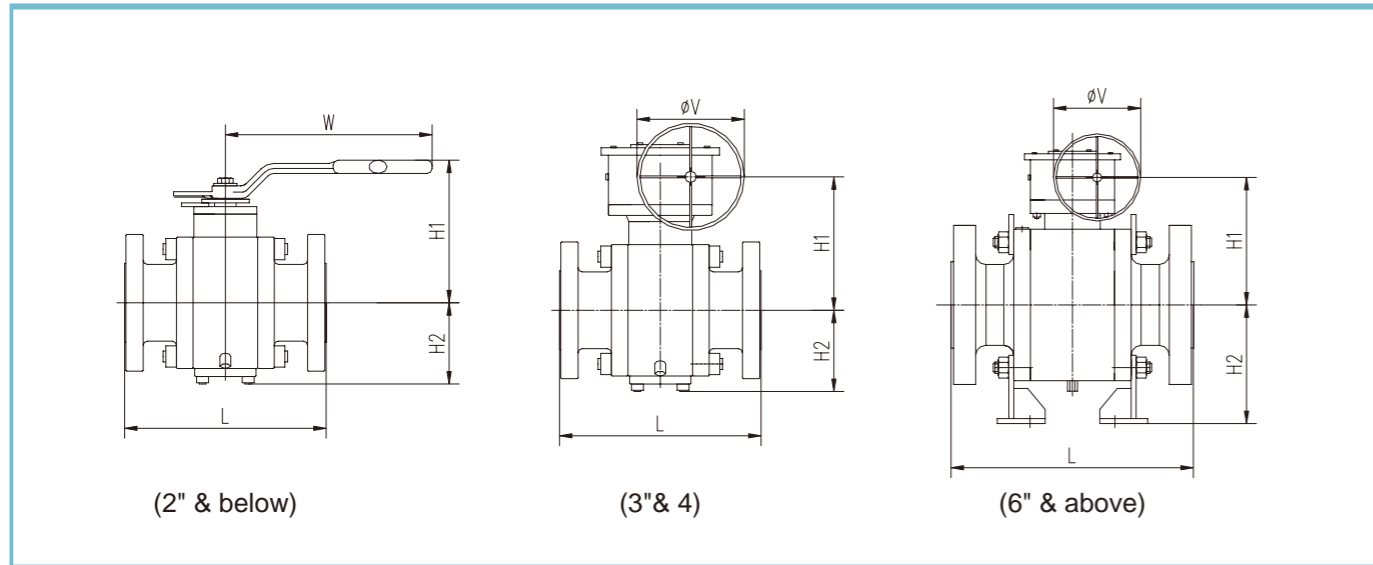

Class 900 Dimensions and weight

In		D		L						H1		H2		W		V		Weight	
				RF		BW		RTJ											
in	mm	in	mm	in	mm	in	mm	in	mm	in	mm	in	mm	in	mm	in	mm	lb	Kg
2	50	1.93	49	14.49	368	14.49	368	14.61	371	7.59	192.8	3.70	94.0	15.75	400			125.66	57
3	80	2.91	74	15.00	381	15.00	381	15.12	384	7.66	194.5	4.25	108.0			11.81	300	185.19	84
4	100	3.94	100	17.99	457	17.99	457	18.11	460	8.88	225.5	5.45	138.5			15.75	400	284.40	129
6	150	5.91	150	24.02	610	24.02	610	24.13	613	11.52	292.5	10.75	273.0			19.69	500	1164.04	528
8	200	7.91	201	29.02	737	29.02	737	29.13	740	13.58	345.0	12.50	317.5			23.62	600	1311.75	595
10	250	9.92	252	32.99	838	32.99	838	33.11	841	18.54	471.0	14.21	361.0			23.62	600	2103.21	954
12	300	11.93	303	37.99	965	37.99	965	38.11	968	22.17	563.0	16.26	413.0			23.62	600	3097.49	1405
14	350	12.68	322	40.51	1029	40.51	1029	40.87	1038	23.64	600.5	17.26	438.5			27.56	700	4259.33	1932
16	400	14.69	373	44.49	1130	44.49	1130	44.88	1140	21.28	540.5	19.27	489.5			29.92	760	5317.54	2412
18	450	16.65	423	47.99	1219	47.99	1219	48.50	1232	22.99	584.0	21.18	538.0			29.92	760	7433.98	3372
20	500	18.54	471	52.01	1321	52.01	1321	52.52	1334	26.12	663.5	22.85	580.5			29.92	760	9153.58	4152
22	550	20.55	522	—	—	—	—	—	—	34.00	863.5	24.70	627.5			29.92	760	11666.85	5292
24	600	22.44	570	60.98	1549	60.98	1549	61.73	1568	35.57	903.5	26.57	675.0			29.92	760	14542.56	6596
26	650	24.29	617	65.00	1651	65.00	1651	65.87	1673	37.80	960.0	28.43	722.0			29.92	760	19701.37	8936
28	700	26.18	665	69.02	1753	69.02	1753	69.88	1775	38.35	974.0	30.30	769.5			29.92	760	26989.84	12242
30	750	28.03	712	74.02	1880	74.02	1880	74.88	1902	43.09	1094.5	31.85	809.0			31.50	800	30270.31	13730
32	800	29.92	760	80.00	2032	80.00	2032	80.87	2054	45.16	1147.0	33.56	852.5			35.43	900	32016.37	14522
34	850	31.81	808	85.00	2159	85.00	2159	86.14	2188	41.50	1054.0	29.36	745.8			35.43	900	46196.49	20954
36	900	33.66	855	90.00	2286	90.00	2286	91.14	2315	42.81	1087.5	30.68	779.3			35.43	900	53318.29	24185

Class 1500 Dimensions and weight

In		D		L						H1		H2		W		V		Weight	
				RF		BW		RTJ											
in	mm	in	mm	in	mm	in	mm	in	mm	in	mm	in	mm	in	mm	in	mm	lb	Kg
2	50	1.93	49	14.49	368	14.49	368	14.61	371	7.59	192.8	3.94	100.0	15.75	400			138.89	63
3	80	2.91	74	18.50	470	18.50	470	18.62	473	8.35	212.0	4.78	121.3			15.75	400	266.21	121
4	100	3.94	100	21.50	546	21.50	546	21.61	549	9.57	243.0	5.98	152.0			15.75	400	425.49	193
6	150	5.67	144	27.76	705	27.76	705	27.99	711	12.42	315.5	11.54	293.0			23.62	600	1572.78	713
8	200	7.56	192	32.76	832	32.76	832	33.11	841	18.27	464.0	13.64	346.5			23.62	600	2039.19	925
10	250	9.41	239	39.02	991	39.02	991	39.37	1000	21.93	557.0	15.67	398.0			27.56	700	3240.46	1470
12	300	11.30	287	44.49	1130	44.49	1130	45.12	1146	20.08	510.0	17.83	453.0			29.92	760	5884.35	2669
14	350	12.40	315	49.49	1257	49.49	1257	50.24	1276	21.20	538.5	18.90	480.0			29.92	760	6101.29	2768
16	400	14.17	360	54.49	1384	54.49	1384	55.39	1407	23.68	601.5	20.77	527.5			29.92	760	7484.24	3395
18	450	15.98	406	60.51	1537	60.51	1537	61.38	1559	30.69	779.5	23.05	585.5			29.92	760	9886.79	4485
20	500	17.87	454	65.51	1664	65.51	1664	66.38	1686	32.46	824.5	25.04	636.0			29.92	760	12194.44	5531
22	550	19.69	500	—	—	—	—	—	—	35.57	903.5	26.69	678.0			35.43	900	15540.65	7049
24	600	21.50	546	76.50	1943	76.50	1943	77.64	1972	40.37	1025.5	28.64	727.5			31.50	800	19391.24	8796

Class 2500 Dimensions and weight

In		D		L						H1		H2		W		V		Weight	
				RF		BW		RTJ											
in	mm	in	mm	in	mm	in	mm	in	mm	in	mm	in	mm	in	mm	in	mm	lb	Kg
2	50	1.65	42	17.76	451	17.76	451	17.87	454	7.24	184	5.26	133.5	15.75	400			238.10	108
3	80	2.44	62	22.76	578	22.76	578	22.99	584	8.64	219.5	6.16	156.5			23.62	600	529.11	240
4	100	3.43	87	26.50	673	26.50	673	26.89	683	10.12	257	7.32	186			23.62	600	1018.53	462
6	150	5.16	131	35.98	914	35.98	914	36.50	927	8.54	217	13.62	346			23.62	600	2058.23	934
8	200	7.05	179	40.24	1022	40.24	1022	40.87	1038	7.72	196	16.18	411			27.56	700	3576.78	1622
10	250	8.78	223	50.00	1270	50.00	1270	50.87	1292	3.35	85	18.43	468			29.92	760	5653.53	2564
12	300	10.43	265	55.98	1422	55.98	1422	56.89	1445	4.29	109	19.92	506			29.92	760	8642.99	3920

Item	Part	Item	Part
1	Body	19	Thrust Washer
2	Cap	20	Bearing
3	Ball	21	Vent Valve
4	Seat Assembly(5+6)	22	Plug
5	Seat Insert	23	Spring
6	Seat Retainer	24	O-Ring
7	Stem	25	O-Ring
8	Pin	26	O-Ring
9	Thrust Washer	27	O-Ring
10	Bearing Support	28	O-Ring
11	Gasket	29	O-Ring
12	Gasket	30	Body Stud
13	Fire Safe Graphite Ring	31	Body Nut
14	Fire Safe Graphite Ring	32	Screw
15	Key	33	Screw
16	Cover	34	Anti-Static Device
17	Top Flange	35	Injection
18	Thrust Washer	36	Injection

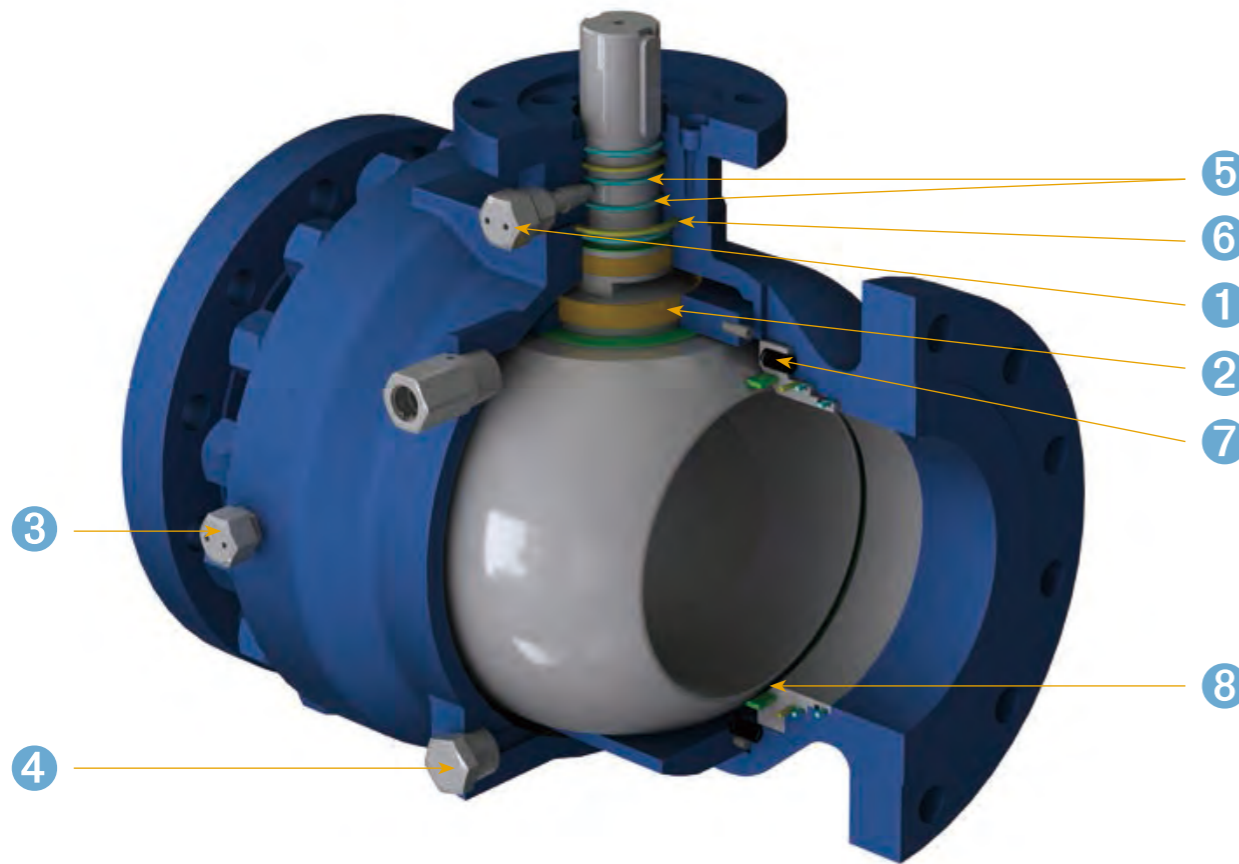

- 1 Emergency Sealant Injection Fitting: Prevents leakage from the stem.
- 2 Blow-out Proof Stem: Stem functions as the backseat to assure stem sealing at all pressures.
- 3 Emergency Sealant Injection Fitting: Prevents leakage from the seat.
- 4 Drain plug : Relieves the body cavity.
- 5 Double Sealing O-rings: Prevents leakage from stem area.
- 6 O-ring & Gasket Combination: Prevents leakage from body connection area.
- 7 Floating Spring: Loaded seats assure sealing, even at low pressures.
- 8 Metal-to-Metal Sealing: When soft seals are deteriorated by fire, seat float to shut off the line media.

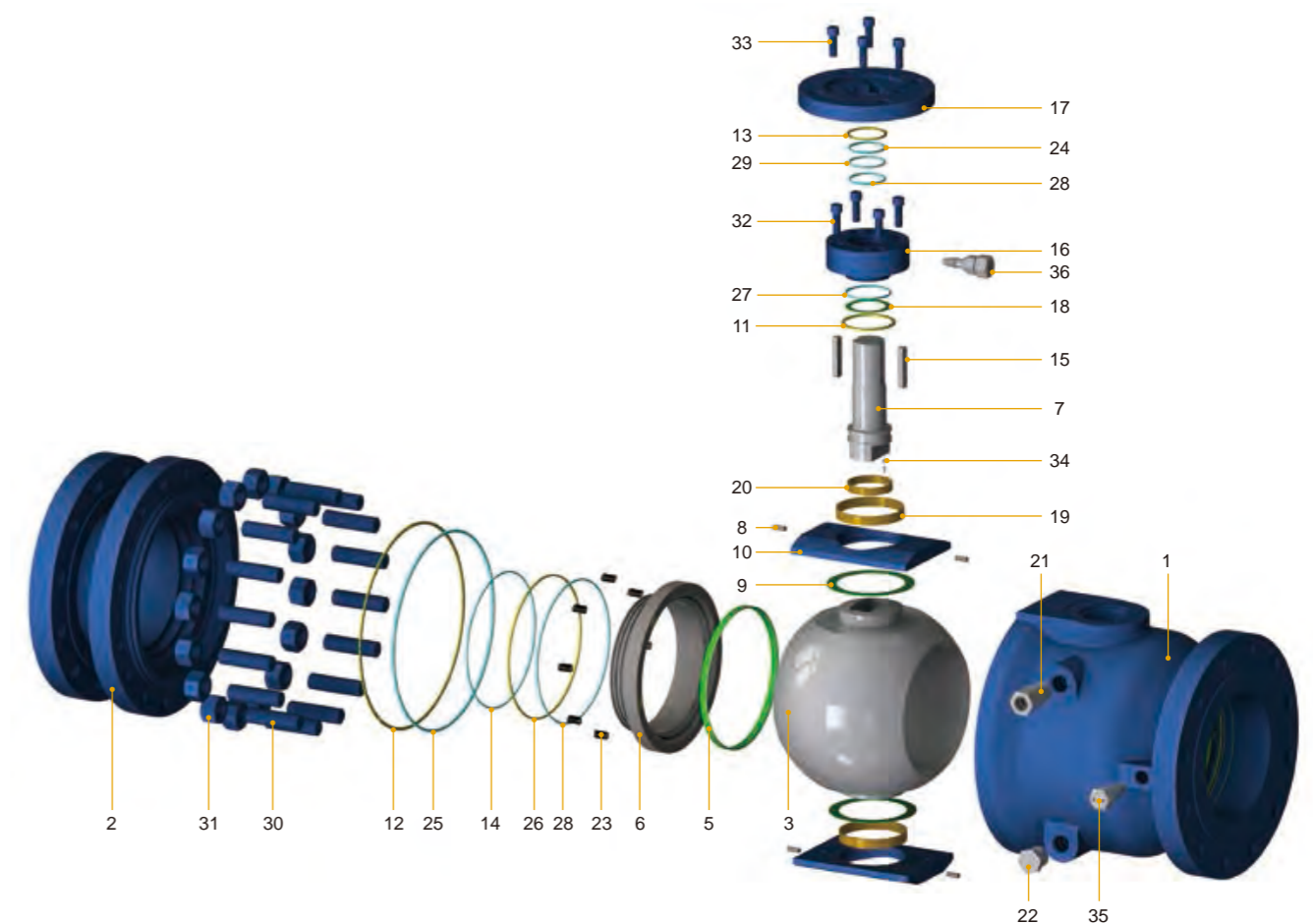

Item	Part	Standard	Stainless Steel	Sour Service	Low Temperature Service
1	Body	ASTM A216-WCB	ASTM A351-CF8M	ASTM A216-WCB	ASTM A352-LCB
2	Cap	ASTM A216-WCB	ASTM A351-CF8M	ASTM A216-WCB	ASTM A352-LCB
3	Ball	ASTM A105N/ENP	ASTM A182 F316	ASTM A105N/ENP	ASTM A350-LF2/ENP
4	Seat Assembly(5+6)	5&6	5&6	5&6	5&6
5	Seat Insert	RPTFE/NYLON/PEEK	RPTFE/NYLON/PEEK	RPTFE/NYLON/PEEK	RPTFE/NYLON/PEEK
6	Seat Retainer	ASTM A105N/ENP	ASTM A182 F316	ASTM A105N/ENP	ASTM A350-LF2/ENP
7	Stem	ASTM A105N/ENP	ASTM A182 F316	ASTM A105N/ENP	ASTM A350-LF2/ENP
8	Pin	Stainless Steel	Stainless Steel	Stainless Steel	Stainless Steel
9	Thrust Washer	PTFE	PTFE	PTFE	PTFE
10	Bearing Support	ASTM A588B/ENP	ASTM A351-CF3M	ASTM A588B/ENP	ASTM A588B/ENP
11	Gasket	316SS+Graphite	316SS+Graphite	316SS+Graphite	316SS+Graphite
12	Gasket	316SS+Graphite	316SS+Graphite	316SS+Graphite	316SS+Graphite
13	Fire Safe Graphite Ring	316SS+Graphite	316SS+Graphite	316SS+Graphite	316SS+Graphite
14	Fire Safe Graphite Ring	316SS+Graphite	316SS+Graphite	316SS+Graphite	316SS+Graphite
15	Key	Carbon Steel	Stainless Steel	Carbon Steel	Stainless Steel
16	Cover	ASTM A105N	ASTM A182 F316	ASTM A105N	ASTM A350-LF2
17	Top Flange	ASTM A105N	ASTM A182 F316	ASTM A105N	ASTM A350-LF2
18	Thrust Washer	PTFE	PTFE	PTFE	PTFE
19	Bearing	316SS+PTFE+MoS2	316SS+PTFE+MoS2	316SS+PTFE+MoS2	316SS+PTFE+MoS2
20	Bearing	316SS+PTFE	316SS+PTFE	316SS+PTFE	316SS+PTFE
21	Vent Valve	Stainless Steel	Stainless Steel	Stainless Steel	Stainless Steel
22	Drain	Stainless Steel	Stainless Steel	Stainless Steel	Stainless Steel
23	Spring	Inconel X-750	Inconel X-750	Inconel X-750	Inconel X-750
24	O-Ring	NBR	NBR	NBR	NBR
25	O-Ring	HNBR/VITON	HNBR/VITON	HNBR/VITON	HNBR/VITON
26	O-Ring	HNBR/VITON	HNBR/VITON	HNBR/VITON	HNBR/VITON
27	O-Ring	HNBR/VITON	HNBR/VITON	HNBR/VITON	HNBR/VITON
28	O-Ring	HNBR/VITON	HNBR/VITON	HNBR/VITON	HNBR/VITON
29	O-Ring	HNBR/VITON	HNBR/VITON	HNBR/VITON	HNBR/VITON
30	Body Stud	ASTM A193-B7	ASTM A193-B8	ASTM A193-B7M	ASTM A320-L7M
31	Body Nut	ASTM A194-2H	ASTM A194-8	ASTM A194-2HM	ASTM A194-7M
32	Screw	ASTM A193-B7	Stainless Steel	ASTM A193-B7M	ASTM A320-L7M
33	Screw	ASTM A193-B7	Stainless Steel	ASTM A193-B7M	ASTM A320-L7M
34	Anti-Static Device	Stainless Steel	Stainless Steel	Stainless Steel	Stainless Steel
35	Injection	Stainless Steel	Stainless Steel	Stainless Steel	Stainless Steel
36	Injection	Stainless Steel	Stainless Steel	Stainless Steel	Stainless Steel

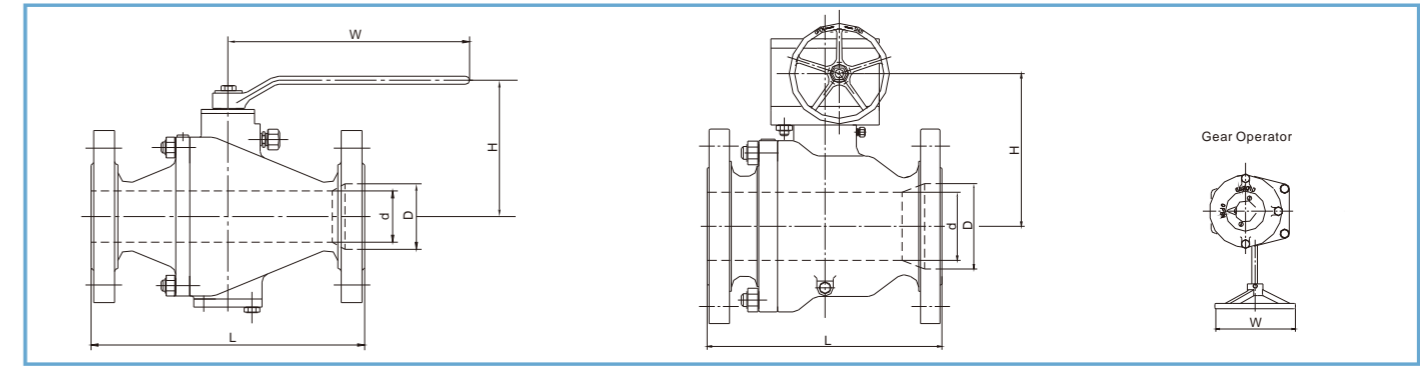

Class 150 Dimensions and weight

Full Port											
Size		d		L		H		W		Weight	
in	mm	in	mm	in	mm	in	mm	in	mm	lb	Kg
2	50	2.01	51	7.01	178	6.50	165	9.06	230	37.5	17
3	80	2.99	76	7.99	203	7.60	193	15.75	400	72.8	33
4	100	4.02	102	9.02	229	9.09	231	18.11	460	110.2	50
6	150	5.98	152	15.51	394	12.95	329	39.37	1000	205.0	93
8	200	7.99	203	17.99	457	15.47	393	19.69	*500	366.0	166
10	250	10.00	254	20.98	533	15.79	401	19.69	*500	601.9	273
12	300	12.01	305	24.02	610	17.36	441	19.69	*500	1047.2	475
14	350	13.27	337	27.01	686	18.94	481	19.69	*500	1256.6	570
16	400	15.24	387	30.00	762	23.54	598	19.69	*500	1715.2	778
18	450	17.24	438	34.02	864	25.31	643	19.69	*500	2061.3	935
20	500	19.25	489	35.98	914	27.87	708	19.69	*500	2623.5	1190
22	550	21.26	540	40.00	1016	31.42	798	19.69	*500	2967.4	1346
24	600	23.27	591	42.01	1067	33.98	863	19.69	*500	3481.0	1579

Reduced Port													
Size		d		D		L		H		W		Weight	
in	mm	in	mm	in	mm	in	mm	in	mm	in	mm	lb	Kg
3*2	80*50	2.01	51	2.99	76	7.99	203	6.50	165	9.06	230	66.1	30
4*3	100*80	2.99	76	4.02	102	9.02	229	7.60	193	15.75	400	103.6	47
6*4	150*100	4.02	102	5.98	152	15.51	394	9.09	231	15.75	400	198.4	90
8*6	200*150	5.98	152	7.99	203	17.99	457	12.95	329	18.11	460	354.9	161
10*8	250*200	7.99	203	10.00	254	20.98	533	15.47	393	39.37	1000	590.8	268
12*10	300*250	10.00	254	12.01	305	24.02	610	15.47	393	19.69	*500	1029.5	467
14*12	350*300	12.01	305	13.27	337	27.01	686	17.36	441	19.69	*500	1234.6	560
16*14	400*350	13.27	337	15.24	387	30.00	762	18.94	481	19.69	*500	1688.7	766
18*16	450*400	15.24	387	17.24	438	34.02	864	23.54	598	19.69	*500	1988.5	902
20*18	500*450	17.24	438	19.25	489	35.98	914	25.31	643	19.69	*500	2491.2	1130
22*20	550*500	19.25	489	21.26	540	40.00	1016	25.31	643	19.69	*500	2866.0	1300
24*20	600*500	19.25	489	23.27	591	42.01	1067	27.87	708	19.69	*500	3351.0	1520

Class 300 Dimensions and weight

Full Port											
Size		d		L		H		W		Weight	
in	mm	in	mm	in	mm	in	mm	in	mm	lb	Kg
2	50	2.01	51	8.50	216	6.50	165	9.06	230	39.7	18
3	80	2.99	76	11.14	283	7.60	193	15.75	400	88.2	40
4	100	4.02	102	12.01	305	9.09	231	2.95	75	138.9	63
6	150	5.98	152	15.87	403	12.95	329	39.37	1000	330.7	150
8	200	7.99	203	19.76	502	15.47	393	59.06	1500	529.1	240
10	250	10.00	254	22.36	568	15.79	401	19.69	*500	672.4	305
12	300	12.01	305	25.51	648	17.36	441	19.69	*500	1117.7	507
14	350	13.27	337	30.00	762	18.94	481	19.69	*500	1327.2	602.
16	400	15.24	387	32.99	838	23.54	598	19.69	*500	2204.6	1000
18	450	17.24	438	35.98	914	25.31	643	19.69	*500	2557.3	1160
20	500	19.25	489	39.02	991	27.87	708	19.69	*500	2910.1	1320
22	550	21.26	540	42.99	1092	31.42	798	19.69	*500	3395.1	1540
24	600	23.27	591	45.00	1143	33.98	863	19.69	*500	4131.4	1874

*Gear Operator

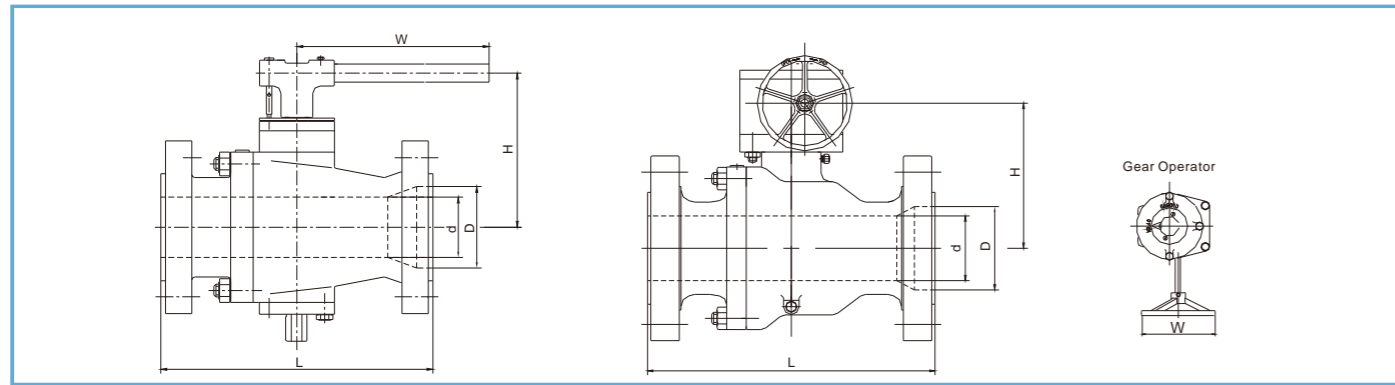

Class 300 Dimensions and weight

Size		d		D		L		H		W		Weight	
in	mm	in	mm	in	mm	in	mm	in	mm	in	mm	lb	Kg
3*2	80*50	2.01	51	2.99	76	11.14	283	6.50	165	9.06	230	83.8	38
4*3	100*80	2.99	76	4.02	102	12.01	305	7.60	193	15.75	400	132.3	60
6*4	150*100	4.02	102	5.98	152	15.87	403	9.09	231	29.53	750	324.1	147
8*6	200*150	5.98	152	7.99	203	19.76	502	12.95	329	39.37	1000	515.9	234
10*8	250*200	7.99	203	10.00	254	22.36	568	15.47	393	59.06	1500	650.4	295
12*10	300*250	10.00	254	12.01	305	25.51	648	15.47	393	19.69	*500	1075.8	488
14*12	350*300	12.01	305	13.27	337	30.00	762	17.36	441	19.69	*500	1256.6	570
16*14	400*350	13.27	337	15.24	387	32.99	838	18.94	481	19.69	*500	2006.2	910
18*16	450*400	15.24	387	17.24	438	35.98	914	23.54	598	19.69	*500	2248.7	1020
20*18	500*450	17.24	438	19.25	489	39.02	991	25.31	643	19.69	*500	2821.9	1280
22*20	550*500	19.25	489	21.26	540	42.99	1092	25.31	643	19.69	*500	2998.2	1360
24*20	600*500	19.25	489	23.27	591	45.00	1143	27.87	708	19.69	*500	3681.7	1670

Class 600 Dimensions and weight

Size		d		L		H		W		Weight	
in	mm	in	mm	in	mm	in	mm	in	mm	lb	Kg
2	50	2.01	51	11.50	292	6.93	176	15.75	400	59.5	27
3	80	2.99	76	14.02	356	9.72	247	29.53	750	110.2	50
4	100	4.02	102	17.01	432	10.87	276	39.37	1000	176.4	80
6	150	5.98	152	22.01	559	14.29	363	59.06	1500	775.6	351
8	200	7.99	203	25.98	660	14.29	363	19.69	*500	771.6	350
10	250	10.00	254	30.98	787	16.77	426	19.69	*500	1322.8	600
12	300	12.01	305	32.99	838	21.57	548	19.69	*500	1807.8	820
14	350	13.27	337	35.00	889	23.54	598	19.69	*500	2491.2	1130
16	400	15.24	387	39.02	991	25.51	648	19.69	*500	3417.1	1550
18	450	17.24	438	42.99	1092	29.13	740	19.69	*500	4629.6	2100
20	500	19.25	489	47.01	1194	31.89	810	19.69	*500	6172.8	2800
24	600	23.27	591	55.00	1397	36.22	920	19.69	*500	7993.8	3626

Size		d		D		L		H		W		Weight	
in	mm	in	mm	in	mm	in	mm	in	mm	in	mm	lb	Kg
3*2	80*50	2.01	51	2.99	76	14.02	356	6.93	176	15.75	400	90.4	41
4*3	100*80	2.99	76	4.02	102	17.01	432	9.72	247	29.53	750	154.3	70
6*4	150*100	4.02	102	5.98	152	22.01	559	10.87	276	39.37	1000	269.0	122
8*6	200*150	5.98	152	7.99	203	25.98	660	14.29	363	59.06	1500	562.2	255
10*8	250*200	7.99	203	10.00	254	30.98	787	14.29	363	19.69	*500	970.0	440
12*10	300*250	10.00	254	12.01	305	32.99	838	16.77	426	19.69	*500	1366.8	620
14*12	350*300	12.01	305	13.27	337	35.00	889	21.57	548	19.69	*500	2336.9	1060
16*14	400*350	13.27	337	15.24	387	39.02	991	23.54	598	19.69	*500	3174.6	1440
18*16	450*400	15.24	387	17.24	438	42.99	1092	25.51	648	19.69	*500	4100.5	1860
20*18	500*450	17.24	438	19.25	489	47.01	1194	29.13	740	19.69	*500	5291.0	2400
24*20	600*500	19.25	489	23.27	591	55.00	1397	31.89	810	19.69	*500	7142.9	3240

*Gear Operator

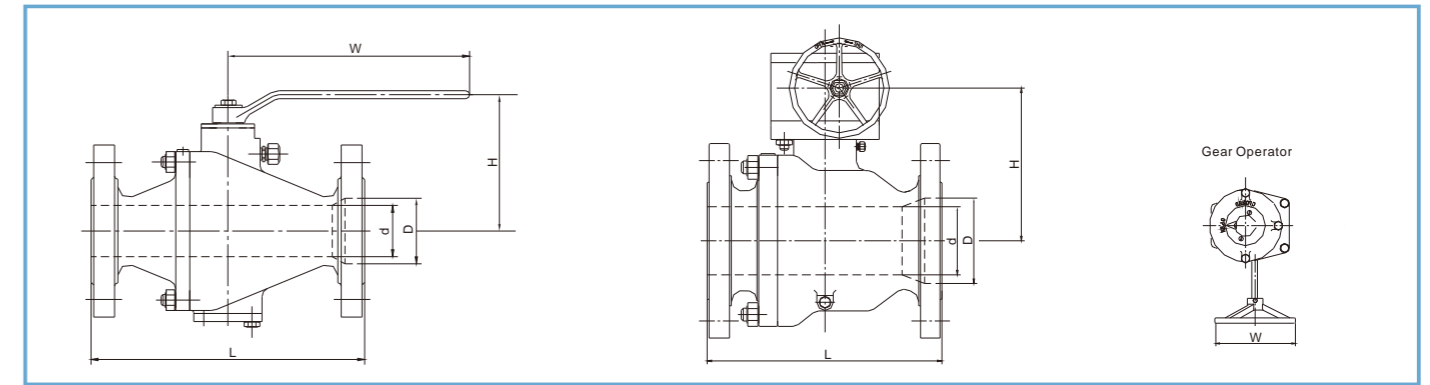

Class 900 Dimensions and weight

Size		d		L		H		W		Weight	
in	mm	in	mm	in	mm	in	mm	in	mm	lb	Kg
2	50	2.01	51	14.49	368	7.56	192	18.11	460	114.6	52
3	80	2.99	76	15.00	381	9.80	249	39.37	1000	213.8	97
4	100	4.02	102	17.99	457	12.40	315	59.06	1500	304.2	138
6	150	5.98	152	24.02	610	12.72	323	19.69	*500	634.9	288
8	200	7.99	203	29.02	737	15.00	381	19.69	*500	987.7	448
10	250	10.00	254	32.99	838	20.39	518	19.69	*500	1649.0	748
12	300	12.01	305	37.99	965	22.36	568	19.69	*500	2244.3	1018
14	350	12.76	324	40.51	1029	26.18	665	19.69	*500	3082.0	1398
16	400	14.76	375	44.49	1130	28.74	730	19.69	*500	4030.0	1828
18	450	16.73	425	47.99	1219	31.30	795	19.69	*500	5132.3	2328
20	500	18.62	473	52.01	1321	32.48	825	24.02	*610	6455.0	2928
24	600	22.52	572	60.98	1549	38.31	973	24.02	*610	9210.8	4178

Size		d		D		L		H		W		Weight	
in	mm	in	mm	in	mm	in	mm	in	mm	in	mm	lb	Kg
3*2	80*50	2.01	51	2.99	76	15.00	381	7.56	192	18.11	460	183.0	83
4*3	100*80	2.99	76	4.02	102	17.99	457	9.80	249	39.37	1000	227.1	103
6*4	150*100	4.02	102	5.98	152	24.02	610	12.40	315	59.06	1500	443.1	201
8*6	200*150	5.98	152	7.99	203	29.02	737	12.72	323	19.69	*500	767.2	348
10*8	250*200	7.99	203	10.00	254	32.99	838	15.00	381	19.69	*500	1318.3	598
12*10	300*250	10.00	254	12.01	305	37.99	965	20.39	518	19.69	*500	1737.2	788
14*12	350*300	12.01	305	12.76	324	40.51	1029	22.36	568	19.69	*500	2425.0	1100
16*14	400*350	12.76	324	14.76	375	44.49	1130	26.18	665	19.69	*500	3130.5	1420
18*16	450*400	14.76	375	16.73	425	47.99	1219	28.74	730	19.69	*500	4250.4	1928
20*18	500*450	16.73	425	18.62	473	52.01	1321	31.30	795	19.69	*500	5352.7	2428
24*20	600*500	18.62	473	22.52	572	60.98	1549	32.48	825	24.02	*610	7888.0	3578

*Gear Operator

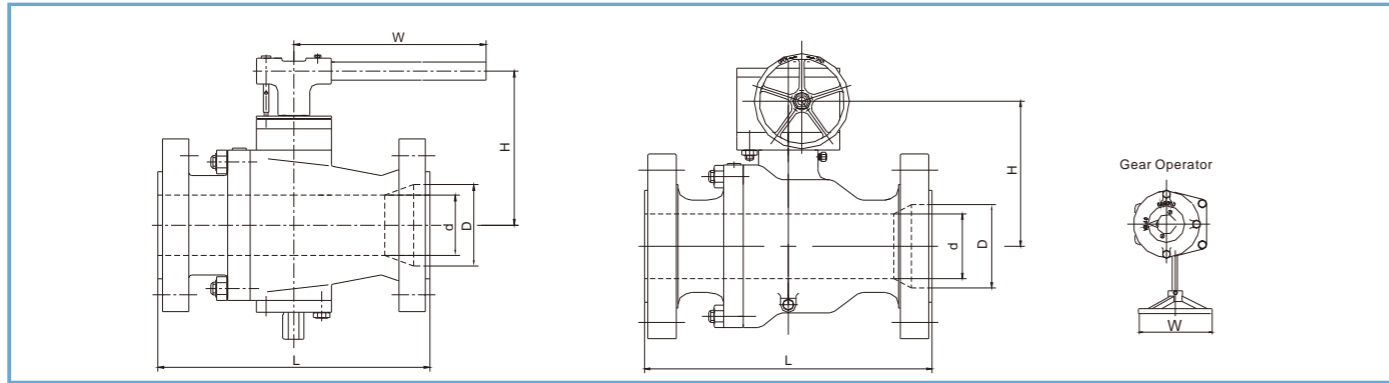

Class 1500 Dimensions and weight

Full Port											
Size		d		L		H		W		Weight	
in	mm	in	mm	in	mm	in	mm	in	mm	lb	Kg
2	50	2.01	51	14.49	368	9.92	252	29.53	750	189.6	86
3	80	2.99	76	18.50	470	11.81	300	59.06	1500	299.8	136
4	100	4.02	102	21.50	546	10.71	272	19.69	*500	487.2	221
6	150	5.75	146	27.76	705	13.43	341	19.69	*500	855.4	388
8	200	7.64	194	32.76	832	19.41	493	19.69	*500	1278.7	580
10	250	9.49	241	39.02	991	22.24	565	19.69	*500	2089.9	948
12	300	11.38	289	44.49	1130	27.56	700	19.69	*500	2949.7	1338
14	350	12.52	318	49.49	1257	29.41	747	19.69	*500	3853.6	1748
16	400	14.25	362	54.49	1384	31.30	795	24.02	*610	4911.8	2228
18	450	16.02	407	60.51	1537	34.53	877	24.02	*610	6283.1	2850
20	500	17.99	457	65.51	1664	38.78	985	24.02	*610	10714.3	4860

Reduced Port													
Size		d		D		L		H		W		Weight	
in	mm	in	mm	in	mm	in	mm	in	mm	in	mm	lb	Kg
3*2	80*50	2.01	51	2.99	76	18.50	470	9.92	252	29.53	750	216.0	98
4*3	100*80	2.99	76	4.02	102	21.50	546	11.81	300	59.06	1500	304.2	138
6*4	150*100	4.02	102	5.75	146	27.76	705	10.71	272	19.69	*500	634.9	288
8*6	200*150	5.75	146	7.64	194	32.76	832	13.43	341	19.69	*500	987.7	448
10*8	250*200	7.64	194	9.49	241	39.02	991	19.41	493	19.69	*500	1649.0	748
12*10	300*250	9.49	241	11.38	289	44.49	1130	22.24	565	19.69	*500	2248.7	1020
14*12	350*300	11.38	289	12.52	318	49.49	1257	27.56	700	19.69	*500	3086.4	1400
16*14	400*350	12.52	318	14.25	362	54.49	1384	29.41	747	19.69	*500	4012.3	1820
18*16	450*400	14.25	362	16.02	407	60.51	1537	31.30	795	24.02	*610	5132.3	2328
20*18	500*450	16.02	407	17.99	457	65.51	1664	34.53	877	24.02	*610	9082.9	4120

*Gear Operator

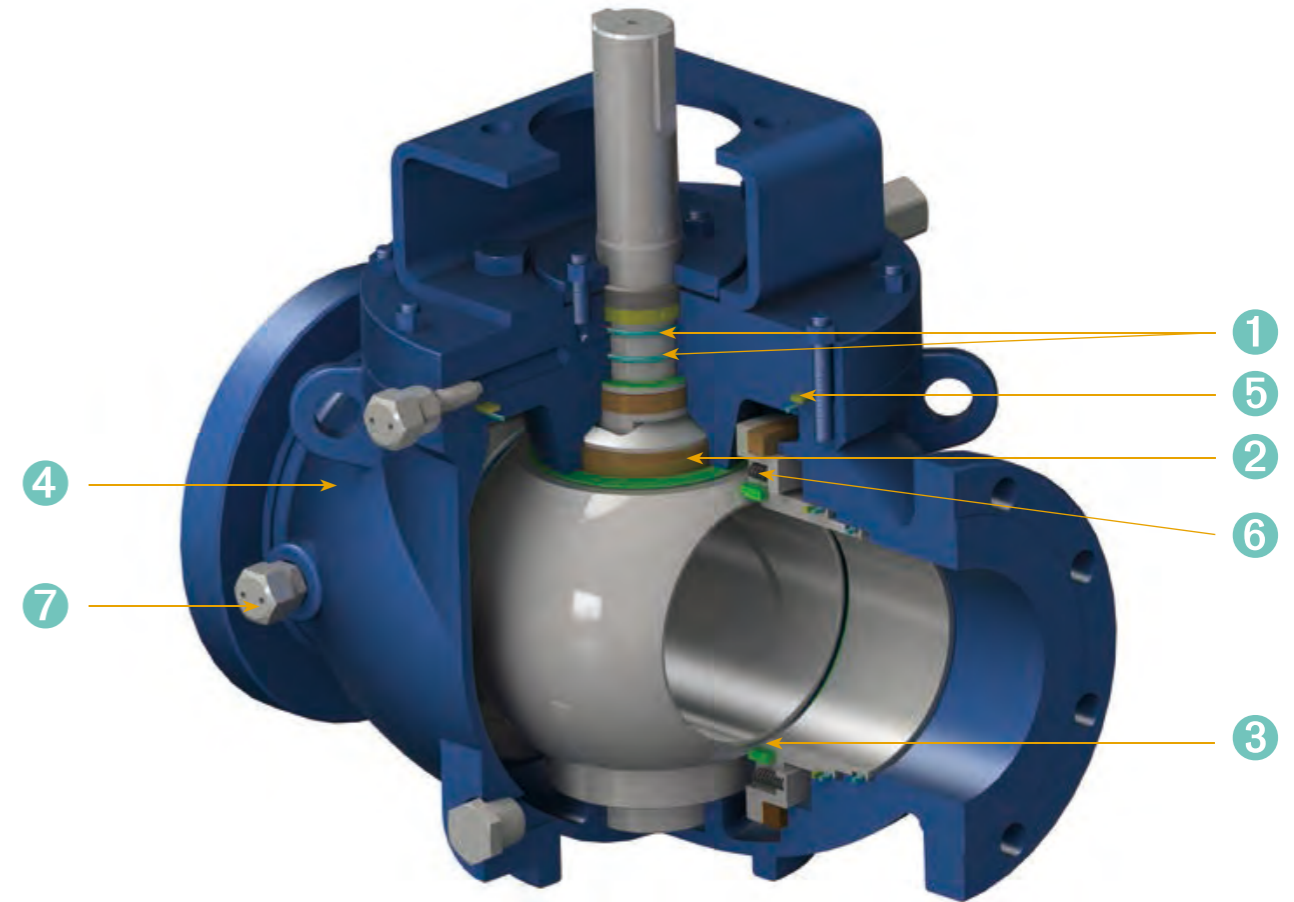

- 1 Two O-ring Seals: Prevent leakage from stem area.
- 2 Blow-out Proof Stem : Safety feature that functions to assure stem sealing at all pressures.
- 3 Back-up Metal to Metal Sealing: If primary soft-seat materials are burned, the metal-to-metal provides shutoff.
- 4 One-piece Body: Same rigidity as that of pipe.
- 5 O-ring & Gasket Combination: Prevents leakage from body connection area.
- 6 Floating Spring-loaded Seats: Assure sealing even at low pressures.
- 7 Emergency Sealant Injection Fitting: Allows external intervention to prevent seat leakage.

Item	Part	Item	Part
1	Body	19	Vent Valve
2	Cap	20	Plug
3	Ball	21	Gland Flange
4	Supporting Ring	22	Gland
5	Seat Insert	23	Packing
6	Seat Retainer	24	Trunnion
7	Spring Seat	25	Seat Spring
8	Stem	26	Anti-Static Device
9	Gasket	27	O-Ring
10	Fire safe Graphite Ring	28	O-Ring
11	Injection	29	O-Ring
12	Injection	30	O-Ring
13	Key	31	Stud
14	Yoke	32	Nut
15	Thrust Washer	33	Body Stud
16	Thrust Washer	34	Body Nut
17	Bearing	35	Screw
18	Bearing		

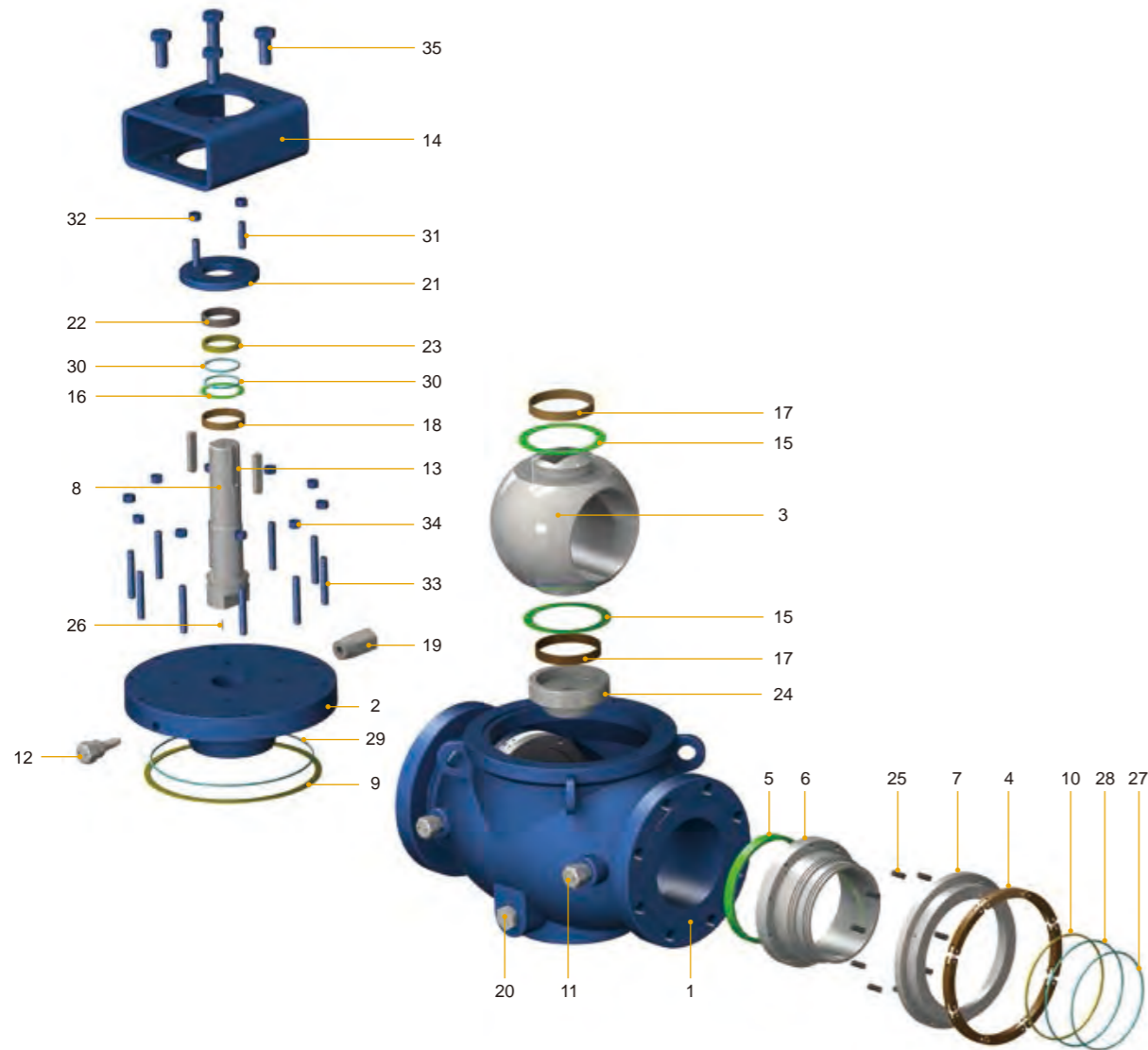

Item	Part	Standard	Stainless Steel	Sour Service	Low Temperature Service
1	Body	ASTM A216-WCB	ASTM A351-CF8M	ASTM A216-WCB	ASTM A352-LCB
2	Cap	ASTM A105N	ASTM A182 F316	ASTM A105N	ASTM A350-LF2
3	Ball	ASTM A105N/ENP	ASTM A182 F316	ASTM A105N/ENP	ASTM A350-LF2/ENP
4	Supporting Ring	Stainless Steel	Stainless Steel	Stainless Steel	Stainless Steel
5	Seat Insert	RPTFE/NYLON/PEEK	RPTFE/NYLON/PEEK	RPTFE/NYLON/PEEK	RPTFE/NYLON/PEEK
6	Seat Retainer	ASTM A105N/ENP	ASTM A182 F316	ASTM A105N/ENP	ASTM A350-LF2/ENP
7	Spring Support	ASTM A105N/ENP	ASTM A182 F316	ASTM A105N/ENP	ASTM A350-LF2/ENP
8	Stem	ASTM A105N/ENP	ASTM A182 F316	ASTM A105N/ENP	ASTM A350-LF2/ENP
9	Gasket	316SS+Graphite	316SS+Graphite	316SS+Graphite	316SS+Graphite
10	Fire Safe Graphite Ring	316SS+Graphite	316SS+Graphite	316SS+Graphite	316SS+Graphite
11	Injection	Stainless Steel	Stainless Steel	Stainless Steel	Stainless Steel
12	Injection	Stainless Steel	Stainless Steel	Stainless Steel	Stainless Steel
13	Key	Carbon Steel	Stainless Steel	Carbon Steel	Stainless Steel
14	Yoke	Carbon Steel	Carbon Steel	Carbon Steel	Carbon Steel
15	Thrust Washer	PTFE	PTFE	PTFE	PTFE
16	Thrust Washer	PTFE	PTFE	PTFE	PTFE
17	Bearing	316SS+PTFE	316SS+PTFE	316SS+PTFE	316SS+PTFE
18	Bearing	316SS+PTFE	316SS+PTFE	316SS+PTFE	316SS+PTFE
19	Vent Valve	Stainless Steel	Stainless Steel	Stainless Steel	Stainless Steel
20	Drain	Stainless Steel	Stainless Steel	Stainless Steel	Stainless Steel
21	Gland Flange	ASTM A105N	Stainless Steel	ASTM A105N	ASTM A350-LF2
22	Gland	Stainless Steel	Stainless Steel	Stainless Steel	Stainless Steel
23	Packing	316SS+Graphite	316SS+Graphite	316SS+Graphite	316SS+Graphite
24	Trunnion	ASTM A105N/ENP	ASTM A182 F316	ASTM A105N/ENP	ASTM A350-LF2/ENP
25	Spring	Inconel X-750	Inconel X-750	Inconel X-750	Inconel X-750
26	Anti-Static Device	Stainless Steel	Stainless Steel	Stainless Steel	Stainless Steel
27	O-Ring	HNBR/VITON	HNBR/VITON	HNBR/VITON	HNBR/VITON
28	O-Ring	HNBR/VITON	HNBR/VITON	HNBR/VITON	HNBR/VITON
29	O-Ring	HNBR/VITON	HNBR/VITON	HNBR/VITON	HNBR/VITON
30	O-Ring	HNBR/VITON	HNBR/VITON	HNBR/VITON	HNBR/VITON
31	Stud	ASTM A193-B7	ASTM A193-B8	ASTM A193-B7M	ASTM A320-L7M
32	Nut	ASTM A194-2H	ASTM A194-8	ASTM A194-2HM	ASTM A194-7M
33	Body Stud	ASTM A193-B7	ASTM A193-B8	ASTM A193-B7M	ASTM A320-L7M
34	Body Nut	ASTM A194-2H	ASTM A194-8	ASTM A194-2HM	ASTM A194-7M
35	Screw	Carbon Steel	Stainless Steel	Carbon Steel	ASTM A320-L7M

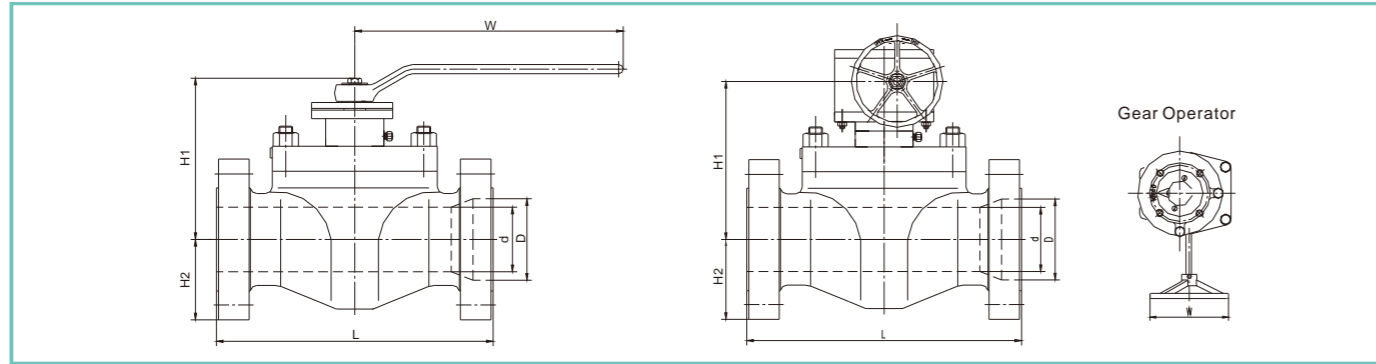

Class 600 Dimensions and weight

Size		D		L		H1		H2		W		Weight	
in	mm	in	mm	in	mm	in	mm	in	mm	in	mm	lb	Kg
1-1/2	40	1.50	38	9.49	241	8.23	209	2.76	70	15.75	400	66.1	30
2	50	2.01	51	11.50	292	7.68	195	4.33	110	15.75	400	83.8	38
3	80	2.99	76	14.02	356	9.45	240	4.33	110	29.53	750	176.4	80
4	100	4.02	102	17.01	432	11.02	280	6.89	175	39.37	1000	330.7	150
6	150	5.98	152	22.01	559	12.01	305	7.68	195	11.81	*300	652.6	296
8	200	7.99	203	25.98	660	15.75	400	11.02	280	11.81	*300	965.6	438
10	250	10.00	254	30.98	787	17.13	435	11.22	285	19.69	*500	1325.0	601
12	300	12.01	305	32.99	838	17.32	440	12.60	320	23.62	*600	1377.9	625
14	350	13.27	337	35.00	889	19.88	505	13.39	340	23.62	*600	2711.6	1230
16	400	15.24	387	39.02	991	23.23	590	16.14	410	23.62	*600	3384.0	1535
18	450	17.24	438	42.99	1092	27.56	700	17.52	445	23.62	*600	4706.8	2135
20	500	19.25	489	47.01	1194	30.51	775	20.08	510	23.62	*600	5820.1	2640
24	600	23.27	591	55.00	1397	33.07	840	25.20	640	23.62	*600	8730.2	3960

Size		d		D		L		H1		H2		W		Weight	
in	mm	in	mm	in	mm	in	mm	in	mm	in	mm	in	mm	lb	Kg
2*1-1/2	50*40	1.50	38	2.01	51	11.50	292	8.23	209	2.76	70	15.75	400	88.2	40
3*2	80*50	2.01	51	2.99	76	14.02	356	7.68	195	4.33	110	15.75	400	119.0	54
4*3	100*80	2.99	76	4.02	102	17.01	432	9.45	240	4.33	110	29.53	750	218.3	99
6*4	150*100	4.02	102	5.98	152	22.01	559	11.02	280	6.89	175	39.37	1000	467.4	212
8*6	200*150	5.98	152	7.99	203	25.98	660	12.01	305	7.68	195	11.81	*300	670.2	304
10*8	250*200	7.99	203	10.00	254	30.98	787	15.75	400	11.02	280	11.81	*300	1124.3	510
12*10	300*250	10.00	254	12.01	305	32.99	838	17.13	435	11.22	285	19.69	*500	1988.5	902
14*12	350*300	12.01	305	13.27	337	35.00	889	17.32	440	12.60	320	23.62	*600	2403.0	1090
16*14	400*350	13.27	337	15.24	387	39.02	991	19.88	505	13.39	340	23.62	*600	2888.0	1310
18*16	450*400	15.24	387	17.24	438	42.99	1092	23.23	590	16.14	410	23.62	*600	3615.5	1640
20*18	500*450	17.24	438	19.25	489	47.01	1194	27.56	700	17.52	445	23.62	*600	5357.1	2430
24*20	600*500	19.25	489	23.27	591	55.00	1397	30.51	775	20.08	510	23.62	*600	7583.8	3440

* Gear Operator

Class 900 Dimensions and weight

Size		D		L		H1		H2		W		Weight	
in	mm	in	mm	in	mm	in	mm	in	mm	in	mm	lb	Kg
1-1/2	40	1.50	38	12.01	305	8.46	215	3.15	80	15.75	400	88.2	40
2	50	2.01	51	14.49	368	7.87	200	4.72	120	29.53	750	114.6	52
3	80	2.99	76	15.00	381	9.45	240	5.12	130	39.37	1000	191.8	87
4	100	4.02	102	17.99	457	11.02	280	6.89	175	59.06	1500	352.7	160
6	150	5.98	152	24.02	610	13.78	350	8.66	220	11.81	*300	848.8	385
8	200	7.99	203	29.02	737	15.35	390	10.24	260	15.75	*400	1234.6	560
10	250	10.00	254	32.99	838	18.90	480	12.20	310	23.62	*600	1807.8	820
12	300	12.01	305	37.99	965	21.18	538	16.14	410	23.62	*600	2480.2	1125

* Gear Operator

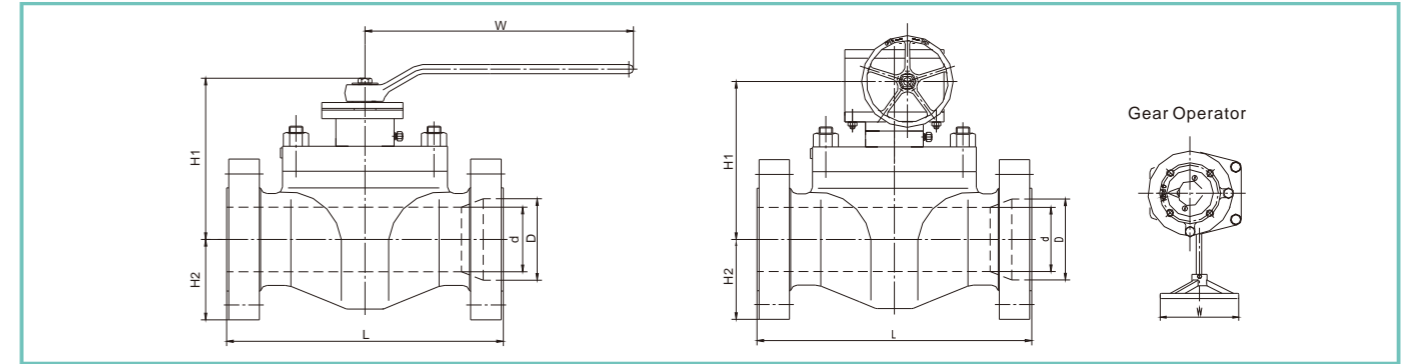

Class 900 Dimensions and weight

Size		d		D		L		H1		H2		W		Weight	
in	mm	in	mm	in	mm	in	mm	in	mm	in	mm	in	mm	lb	Kg
2*1-1/2	50*40	1.50	38	2.01	51	14.49	368	8.46	215	3.15	80	15.75	400	97.0	44
3*1-1/2	80*40	2.01	51	2.99	76	15.00	381	7.87	200	4.72	120	29.53	750	123.5	56
4*3	100*80	2.99	76	4.02	102	17.99	457	9.45	240	9.45	240	39.37	1000	207.2	94
6*4	150*100	4.02	102	5.98	152	24.02	610	11.02	280	11.02	280	59.06	1500	498.2	226
8*6	200*150	5.98	152	7.99	203	29.02	737	13.78	350	13.78	350	11.81	*300	1058.2	480
10*8	250*200	7.99	203	10.00	254	32.99	838	15.35	390	15.35	390	15.75	*400	1433.0	650
12*10	300*250	10.00	254	12.01	305	37.99	965	18.90	480	18.90	480	23.62	*600	1913.6	868

* Gear Operator

Class 1500 Dimensions and weight

Size		D		L		H1		H2		W		Weight	
in	mm	in	mm	in	mm	in	mm	in	mm	in	mm	lb	Kg
1-1/2	40	1.50	38	12.01	305	8.66	220	3.54	90	15.75	400	88.2	40
2	50	2.01	51	14.49	368	8.07	205	4.72	120	29.53	750	132.3	60
3	80	2.99	76	18.50	470	8.27	210	4.92	125	39.37	1000	253.5	115
4	100	4.02	102	21.50	546	9.65	245	6.30	160	11.81	*300	427.7	194
6	150	5.75	146	27.76	705	13.19	335	10.04	255	15.75	*400	1278.7	580
8	200	7.64	194	32.76	832	16.81	427	13.39	340	19.69	*500	1657.8	752
10	250	9.49	241	39.02	991	19.76	502	15.00	381	23.62	*600	2634.5	1195
12	300	11.38	289	44.49	1130	20.98	533	17.24	438	23.62	*600	4784.0	2170

Size		d		D		L		H1		H2		W		Weight	
in	mm	in	mm	in	mm	in	mm	in	mm	in	mm	in	mm	lb	Kg
2*1-1/2	50*40	1.50	38	2.01	51	14.49	368	8.66	220	3.54	90	15.75	400	97.0	44
3*1-1/2	80*40	2.01	51	2.99	76	18.50	470	8.07	205	4.72	120	29.53	750	180.8	82
4*3	100*80	2.99	76	4.02	102	21.50	546	8.27	210	4.92	125	39.37	1000	330.7	150
6*4	150*100	4.02	102	5.75	146	27.76	705	9.65	245	6.30	160	11.81	*300	650.4	295
8*6	200*150	5.75	146	7.64	194	32.76	832	13.19	335	10.04	255	15.75	*400	1521.2	690
10*8	250*200	7.64	194	9.49	241	39.02	991	16.81	427	13.39	340	19.69	*500	2050.3	930
12*10	300*250	9.49	241	11.38	289	44.49	1130	19.76	502	15.00	381	23.62	*600	2954.1	1340

* Gear Operator

Seat

Properties		PTFE	NYLON	PEEK	PCTFE	DEVLON V
Temperature Range °F		-328~428	-58~248	-148~500	-328~302	-148~302
Temperature Range °C		-100~200	-50~120	-100~260	-200~150	-100~150
Pressure Rating		150~600	150~1500	150~2500	150~600	150~1500
Mechanical Property	Hardness (D)	58	72	88	85	78
	Tensile Strength(MPa)	14~34	55.2	134	35.9	79.9
	Tensile Elongation(Break,%)	350	250	2.2	150	5.4
Physical Property	Specific Gravity (g/cm ³)	2.17	1.02	1.44	2.12	1.14
	Water Absorption 24hrs(%)	0.00	1	0.06	0.00	0.1
	Water Absorption saturation	<0.01	1.60	.2	<0.01	3
Service Application		Chemical & low temperature	High Pressure & Hydrocarbon	High pressure & temperature	Cryogenic	High Pressure & Hydrocarbon

Sealing

Type	HNBR	VITON	FFKM
Temperature Range °F	-40~302	-4~392	-4~620
Temperature Range °C	-40~150	-20~200	-20~327
Specific Gravity (g/cm ³)	1.34	1.85	2
Hardness (shore A)	75	75	75

* Other elastomer materials are available upon request.

Operating Torque

In	Class 150(NYLON)		Class 300(NYLON)		Class 400(NYLON)		Class 600(NYLON)		Class 900(NYLON)		Class 1500(NYLON)		Class 2500(PEEK)	
	N.m	Ft/Lbs	N.m	Ft/Lbs	N.m	Ft/Lbs	N.m	Ft/Lbs	N.m	Ft/Lbs	N.m	Ft/Lbs	N.m	Ft/Lbs
1-1/2	40	29.52	50	36.90	58	42.81	80	59.05	130	95.95	240	177.14	290	214.04
2	50	36.90	70	51.66	75	55.35	120	88.57	180	132.85	250	184.52	380	280.46
3	60	44.28	100	73.81	150	110.71	240	177.14	400	295.23	530	391.17	780	575.69
4	100	73.81	210	154.99	330	243.56	500	369.03	670	494.50	900	664.26	1300	959.48
6	420	309.99	600	442.84	650	479.74	900	664.26	1820	1343.27	2040	1505.65	4850	3579.60
8	700	516.64	1100	811.87	1300	959.48	1500	1107.09	2560	1889.44	4790	3535.32	6900	5092.63
10	1100	811.87	1800	1328.51	2000	1476.13	2750	2029.67	4510	3328.66	8230	6074.26	13600	10037.65
12	1600	1180.90	2500	1845.16	3153	2327.11	3600	2657.03	6824	5036.54	10340	7631.57	23100	17049.25
14	1950	1439.22	3200	2361.80	3800	2804.64	4700	3468.89	8250	6089.02	12120	8945.32		
16	2500	1845.16	3500	2583.22	4000	2952.25	5470	4037.20	9940	7336.34	14920	11011.89		
18	3400	2509.41	5510	4066.72	7000	5166.44	9000	6642.56	14630	10797.86	27230	20097.44		
20	4600	3395.09	7500	5535.47	9000	6642.56	11000	8118.69	20000	14761.25	32830	24230.59		
22	5200	3837.93	9000	6642.56	11000	8118.69	14630	10797.86	25400	18746.79	39420	29094.43		
24	6774	4999.64	11150	8229.40	13450	9926.94	17950	13248.22	29900	22068.07	46320	34187.06		
26	8000	5904.50	13360	9860.52	14700	10849.52	21640	15971.67	34950	25795.29	55430	40910.81		
28	8600	6347.34	14200	10480.49	18200	13432.74	24340	17964.44	38780	28622.07	70650	52144.12		
30	9233	6814.53	16660	12296.12	20230	14931.01	32510	23994.41	46610	34401.10	75000	55354.69		
32	11810	8716.52	19500	14392.22	28240	20842.89	37600	27751.15	58230	42977.38				
34	13330	9838.37	21380	15779.78	31140	22983.27	41800	30851.02	63750	47051.49				
36	14214	10490.82	29375	21680.59	35520	26215.98	47570	35109.64	72600	53583.34				

Note:

- Torque is calculated based on normal temperature.
- Torque shown in this table is to be used as a guide for actuator selection. A safety factor of 1.3~1.5 is recommended for actuator sizing.
- Torque may be changed depending on fluids and trim materials.

Flow Coefficient (Cv value) Specification

Size (inch)	Class 150	Class 300	Class 600	Class 900	Class 1500
1/2	25	25	20	16	16
3/4	56	56	48	34	34
1	95	95	64	55	55
1-1/2	308	308	308	165	165
2	500	430	370	320	320
3	1360	1100	1020	920	820
4	2500	2000	1850	1760	1600
6	5300	5250	4400	4300	4150
8	10750	10100	8450	8475	8010
10	17500	16820	14250	14160	13220
12	26750	25950	22550	21200	18800
14	31850	30900	28500	26700	24180
16	44000	42600	38150	36600	33150
18	58000	55870	51150	49000	45703
20	75500	72500	68500	64600	60750
22	91770	86850	80150		
24	113400	109340	98860		

Notes:

- All sizes belong to full port.
- Pressure ratings are per API 6D.

Method of Calculating Flow

The Flow Coefficient Cv value is the flow rate of water (gallons/minute) through a fully open valve with a pressure drop of 1 psi to find the flow of liquid through the valve with Cv, using the following formulas.

Liquid Flow:

$$Q_L = C_v(P/G)^{1/2}$$

QL = Flow rate of liquid (gal./min.)
P = differential pressure across the valve
G = specific gravity of liquid (for water, G=1)

Gas Flow:

$$Q_g = 61C_v(P_2P/g)^{1/2}$$

(For non-critical flow, P/P<1.0)
QL = Flow rate of gas (CFH at STP)
P2 = outlet pressure (psia)
g = specific gravity of gas (for air, g=1.0)